

Panel Power Interface datasheet (KNX)

Instruction Manual



MPFPIT-***-KT.17

Before using this product, please read this manual carefully and keep it properly!

Document Version: C

◆◆ Overview

The HDL KNX 2CH10A relay base / 4CH10A relay base communicates and controls via the KNX protocol. When installed on the panel, it is placed in an 86 base box and serves as the power base for the panel. It can control the relay circuits of the base through the KNX bus, enabling intelligent control of household lighting, curtains, fans, sockets, and other electrical devices.

Product name	Model No.	Remark
Panel Power Interface With 2CH 10A Relay	MPFPIT-0210-KT.17	Applicable to the Chinese national standard 86 wall box, shipped without base bracket
Panel Power Interface With 4CH 10A Relay	MPFPIT-0410-KT.17	Applicable to the Chinese national standard 86 wall box, shipped without base bracket

◆◆ Appearance

KNX Panel Power Interface (relay base) :

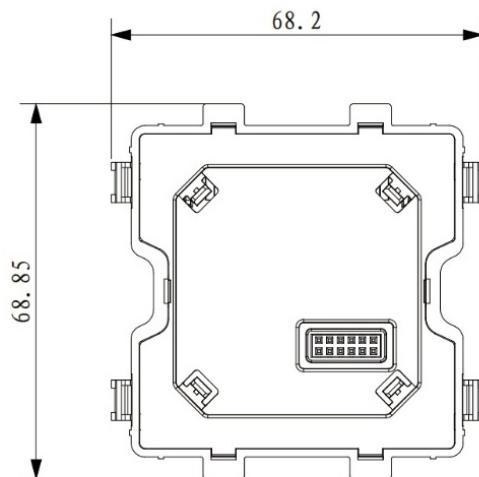

Figures 1

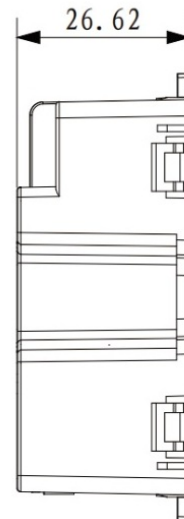

Figures 2

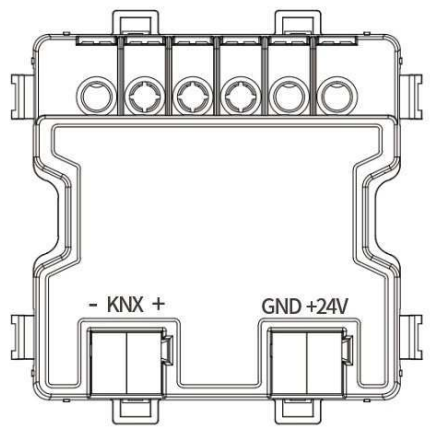

Figures 3

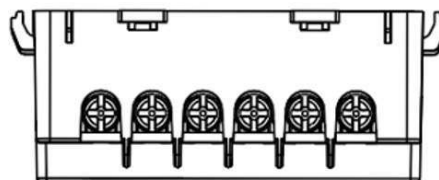

Figures 4

Product Appearance - See Figures 3&4

1. Communication Interface: Provides working voltage and communication signals.
2. KNX communication interface
3. Connection terminal for relay channel

◆◆ Technical Data

Item	Parameter
Rated voltage	24V DC
Working voltage	21V~30V DC
Rated current	400mA
Output power	1A/5V DC
Input voltage	MPFPIT-0210-KT.17: AC100~240V, 50/60Hz MPFPIT-0410-KT.17: AC100~240V, 50/60Hz
Output channel	MPFPIT-0210-KT.17: 2CH, 10A/CH MPFPIT-0410-KT.17: 4CH, 10A/CH
Communication protocol	KNX
Cable diameter of Buspro terminal	0.6-0.8mm
Working temperature	-5°C~45°C
Working relative humidity	≤90%RH, non-condensed
Storage temperature	-20°C~60°C
Storage relative humidity	≤93%

◆◆ Specifications

Item	Parameter
Dimensions (W X H X D)	68.2mm×68.85mm×26.62mm
Net weight (Without bracket)	MPFPIT-0210-KT.17: 60g MPFPIT-0410-KT.17: 77.5g
Housing material	PC
Installation	Wall box (See Figure 6)
IP degree (compliant with EN 60529)	IP20

◆◆ Safety Precaution

- Installation and commissioning of this equipment must be carried out by us or by an organization appointed by us. The planning and construction of the electrical connection of this equipment must comply with the relevant local safety standards and regulations.
- Any consequences caused by failure to install and wire according to this instruction are not related to our company.
- Please do not privately disassemble or replace any parts of the product. Otherwise, it may cause mechanical fault, electric shock, fire or personal injuries.
- Please refer all maintenance work to our after-sales department or designated organization, the warranty of this product does not apply to the failure caused by the user's disassembly of the product.

◆◆ Wiring

- When a relay power interface is used, the panel can control the switching status of each circuit of the connected wireless device. For example, if a light is connected, it can be turned on or off by controlling the panel.
- Please wire according to HDL standards: KNX+, KNX-, GND and +24V.

Panel Power Interface With 2CH/4CH 10A Relay wiring:

Note: Only 86 type wall box with depth≥50mm is supported.

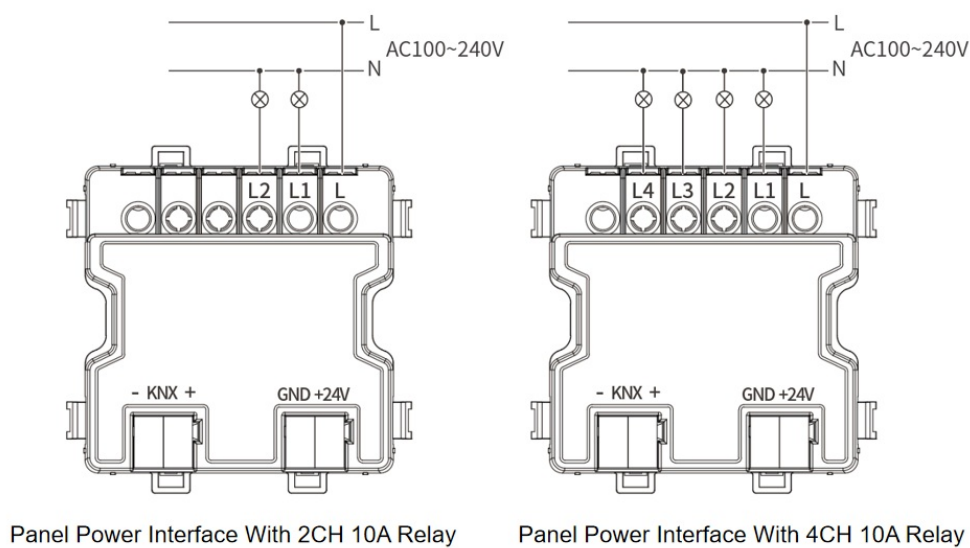

Figure 7

◆◆ Installation

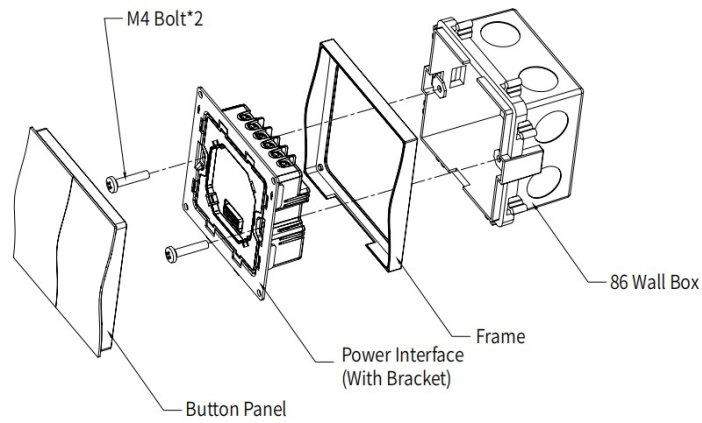

Figure 6

Installation of the device - see Figure 6

Step ①: Install the wall box (86 wall box, the depth of wall box should not be less than 50mm) on the wall and lead out the AC high-voltage wire and signal cable. Connect the strong wire of the relay interface and the signal cable, and pay attention to safe and reliable wiring.

Step ②: Use screws to fix the relay power interface in the wall box.

Step ③: Install the panel on the relay power interface.

Step ④: Install the frame.

◆◆ Disassembly

Warning: Before performing any installation or disassembly procedures on the device, it is crucial to disconnect the device from all voltage sources.

Step 1. It is recommended to use a screwdriver to loosen the frame from the opening.

Step 2. After taking off the panel, use a Phillips screwdriver to remove the power interface.

◆◆ Operation

Properly wire and get the device power on.

◆◆ Packing List

- KNX Panel Power Interface *1
- M4 x 40mm long screws*2
- M4 x 25mm short screws*2

◆◆ Warranty

Warranty period (five years from the date of invoice), if the product fails in normal use, the user can go to the nearest authorized institution with a valid warranty card to obtain free maintenance.

In the following cases, HDL regards the user as giving up the relevant services promised under the warranty and the user shall bear the corresponding responsibility and shall not be entitled to the free warranty:

- Failure of the device caused by force majeure factors.
- The user has placed the device in a transportation or use environment that does not comply with the statements in the product instructions or technical manuals.
- Unauthorized disassembly of the product by the user.
- Promises not made officially by HDL to the user that are beyond the scope of the warranty are the responsibility of the promisor.

HDL reserves the right to update or change the product without prior notice to the user, please visit the HDL website for answers to your questions and the latest product information.

The final interpretation right of the warranty regulations belongs to HDL.

◆◆ Copyright Statement

HDL has all the intellectual property rights to this document and contents thereof. Reproduction or distribution for third parties are prohibited without written authorization from HDL. Any infringement of HDL's intellectual property rights will be investigated the legal liability.

The contents of this document will be updated as the updates of product versions or other reasons. Unless otherwise agreed upon, this document is to be used as a guidance only. All the statements, information and recommendations in this document makes no warranty expressed or implied.

© 2024 HDL Automation Co., Ltd. All rights reserved.

Update History:

The form below contains the information of every update. The latest version contains all the updates of all former versions.

Version	Update Information	Date
V1.0	Initial release	September 28, 2024

◆◆ Technical Support

E-mail: hdtickets@hdlautomation.com

Website: <https://www.hdlautomation.com>

◆◆ Troubleshooting

E-mail: hdtickets@hdlautomation.com

Website: <https://www.hdlautomation.com>