

Curtain Motor

Instruction Manual



MWC1-KT.10

Before using this product, please read this manual carefully and keep it properly!

Document Version: C

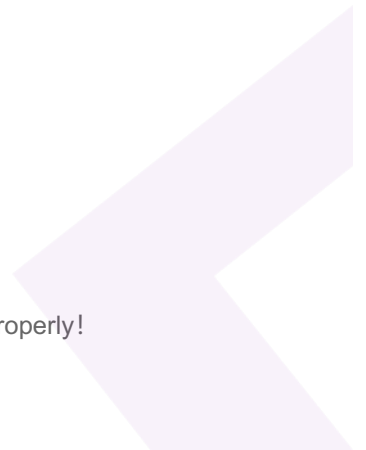

◆◆ Overview

Curtain Motor (Model: MWC1-KT.10; hereinafter referred to as the “product” or “device”) is designed to drive curtain track, such as open or close the curtain cloth. Additionally, the device is compatible with commissioning software and mobile APP. Upon proper installation and commissioning, it is able to integrate the device into smart room system, helping end users easily and conveniently remote control their curtains.

Note: The pictures and illustrations provided in this instruction manual are for reference purposes only, and the actual product may differ.

Key Functions:

- KNX communication protocol
- Curtain control: Open / close / stop / open or close at specific percentage
- Touch start: The device supports "Touch Start" by default. This means, when users gently pull the curtain cloth towards any direction, curtain motor will be activated to work and automatically complete the preset travel.
- Auto travel limit: After setting the motor travel limit, the motor will automatically complete the pre-set travel.
- Auto modification while detecting obstacles: When single side of curtain cloth encounters obstacles, the motor will automatically modify its travel limit.
- Auto pause while detecting obstruction: When curtain cloth encounters obstruction, the motor will automatically stop running.
- Soft start / stop: The motor slows down before it reaches the travel limit point, which is designed to effectively protect the motor and lengthen its service life, as well as reduce motorised noise.
- When the device starts up for the first time after power off then on, it will automatically proceed travel calibration.
- Factory setting can be restored by commissioning software or programming button.
- Through commissioning software, users can proceed advanced settings for the device, including functional configuration, data backup, data upload or download.
- On-line / Manually update for device firmware
- Compatible with bi-channel or multi-channel remote controllers (optional)

◆◆ Appearance

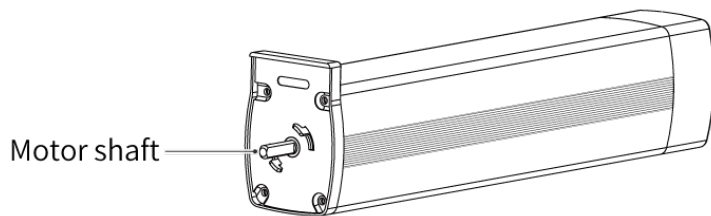

Figure 1

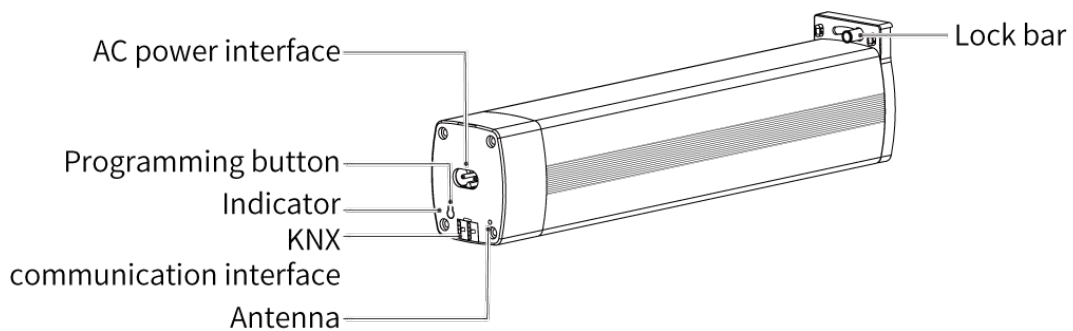

Figure 2

◆◆ Technical Data

Motor input voltage	100 - 240V AC, 50/60Hz
Motor rated consumption	22W
KNX rated voltage	30V DC
KNX rated current	8mA/30V DC
Motor torque	1.2 N·m
Motor rotate speed	90rpm
Motor maximum load-bearing	50kg
Motor sound level	< 30dB ,at silent mode
Communication protocol	KNX
Working temperature	-5°C ~ 45°C
Working relative humidity	≤90%RH, non-condensed
Storage temperature	-20°C ~ 60°C
Storage relative humidity	≤93%RH

◆◆ Specifications

Dimensions (W X H X D)	296×71×50.6mm (See Figure 3 - 5)
Net weight	724g
Housing material	PC, aluminium
Installation	Guide rail (See Figure 7 & 8)
IP degree (compliant with EN 60529)	IP41
Insulation grade	F

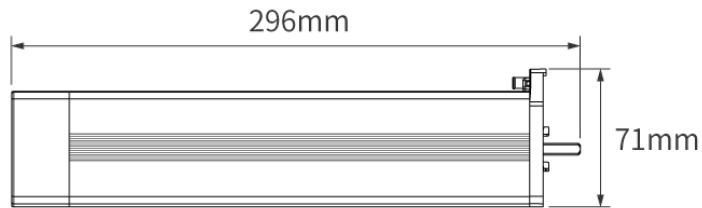

Figure 3

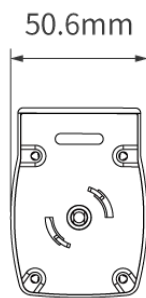

Figure 4

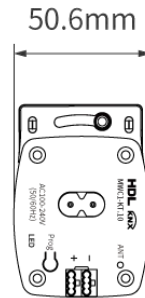

Figure 5

◆◆ Safety Precaution

Danger:

Please do not privately disassemble or replace any parts of the product. Otherwise, it may cause mechanical fault, electric shock, fire or personal injuries.

Warning:

- The installation and testing for the product must be carried out by HDL Automation Co., Ltd. (hereinafter referred to as HDL) or its appointed service agencies. The electric construction shall comply with local laws and safety regulations.
- HDL will not be responsible for any consequence caused by the inexpert or faulty installation and wiring methods, which are not in accordance with the instructions contained in this datasheet.
- Please contact HDL after-sales departments or our designated service agencies for your maintenance service. Product failures caused by private disassembly are not subject to the warranty.

Caution:

- Before performing any installation or disassembly procedures, any maintenance or cleaning procedures on the device, it is crucial to disconnect the device from all voltage sources. This step is necessary to ensure the safety of the technician and prevent any potential damage to the device.
- Do not use corrosive liquid to wipe the device body, especially the interface, so to avoid damage to the device.
- Do not wipe the device with a damp cloth.
- Prior to performing maintenance or cleaning on the device, disconnect the device from all voltage sources, to avoid electric leakage and electric shock.
- Kindly take note that the installation of the aforementioned device is recommended to be conducted in an indoor environment, with due consideration given to the avoidance of exposure to external factors such as humidity and high temperatures.
- After all of the cables are terminated, check for correct and good terminations.
- Kindly take note that the installation of the aforementioned device is recommended to be conducted in an indoor environment.
- It is strictly forbidden to apply any extra items whose weight exceed the motor or guide rail maximum load-bearing to the curtain track; DO NOT climb the curtain.
- When installing the motor onto the guide rail, be sure to check if the motor has been tightly attached in place. Otherwise, it will cause the motor to fall, resulting in product damage or personal injury.

◆◆ Wiring

Tips: After all of the cables are terminated, check for correct and good terminations.

Note: In addition to KNX connection, please note to connect the device with 220V AC power supply.

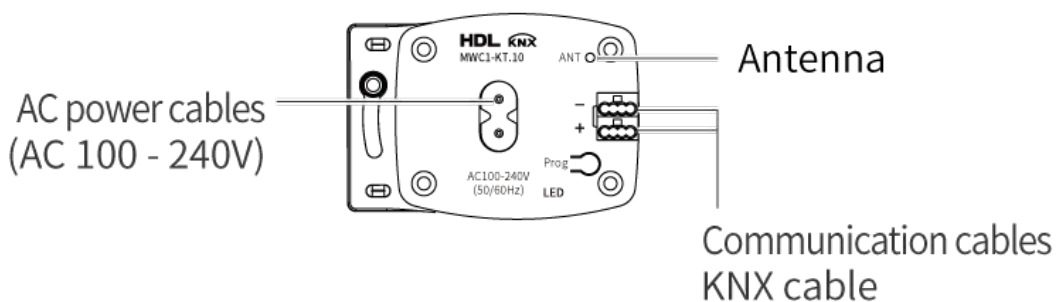

Figure 6

KNX Cable Guide

KNX	KNX Cable
+	Red
-	Black

◆◆ Installation

Warning: Before performing any installation procedures on the device, it is crucial to disconnect the device from all voltage sources. This step is necessary to ensure the safety of the technician and prevent any potential damage to the device.

Tips: The device should be mounted onto the guide rail. Thus, please make sure the guide rail has been installed properly.

Step 1. Pull the lock bar out, then slide it in the direction indicated by arrow 1.

Step 2. Insert the motor shaft to the guide rail.

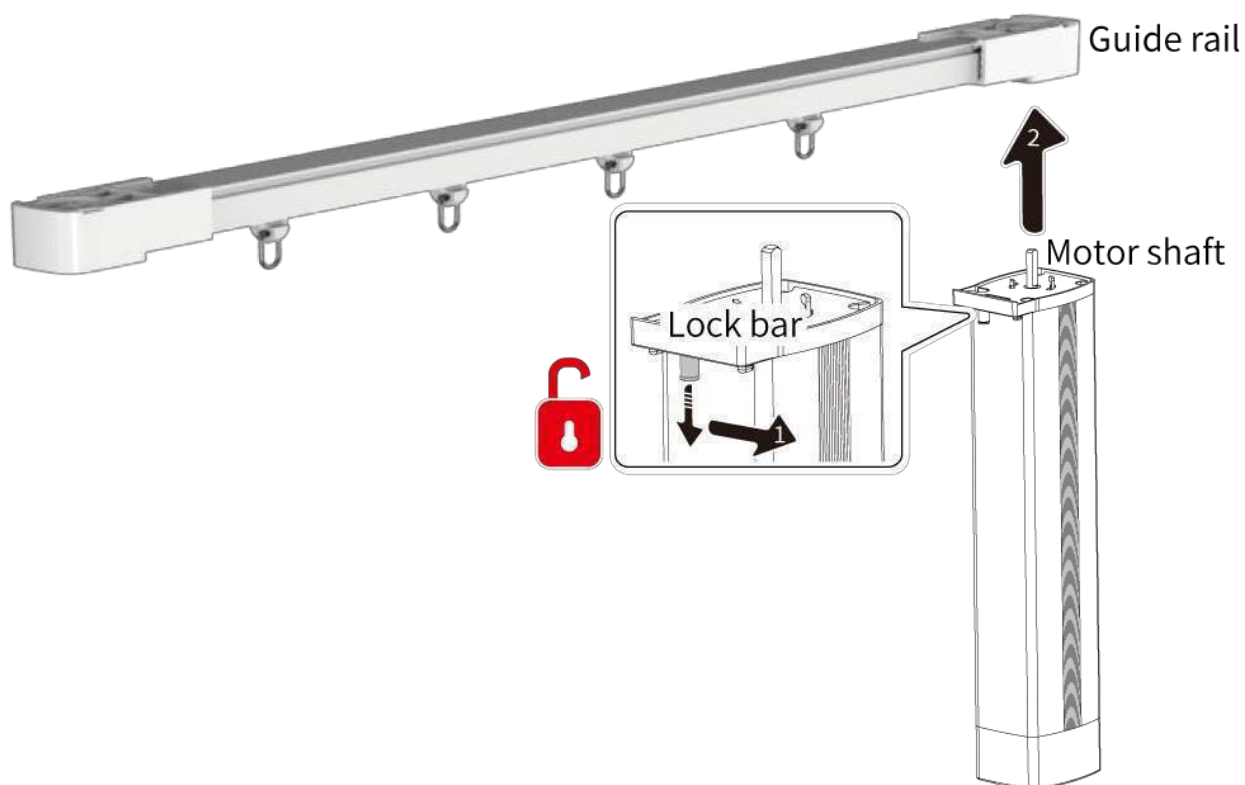

Figure 7

Step 3. Make sure the motor is tightly attached with the guide rail, then slide the lock bar back in the direction indicated by arrow 3. In this way, the motor can be locked.

Note: After installation, check for correct and good terminations. Before powering on, please ensure the device is completely mounted onto the guide rail.

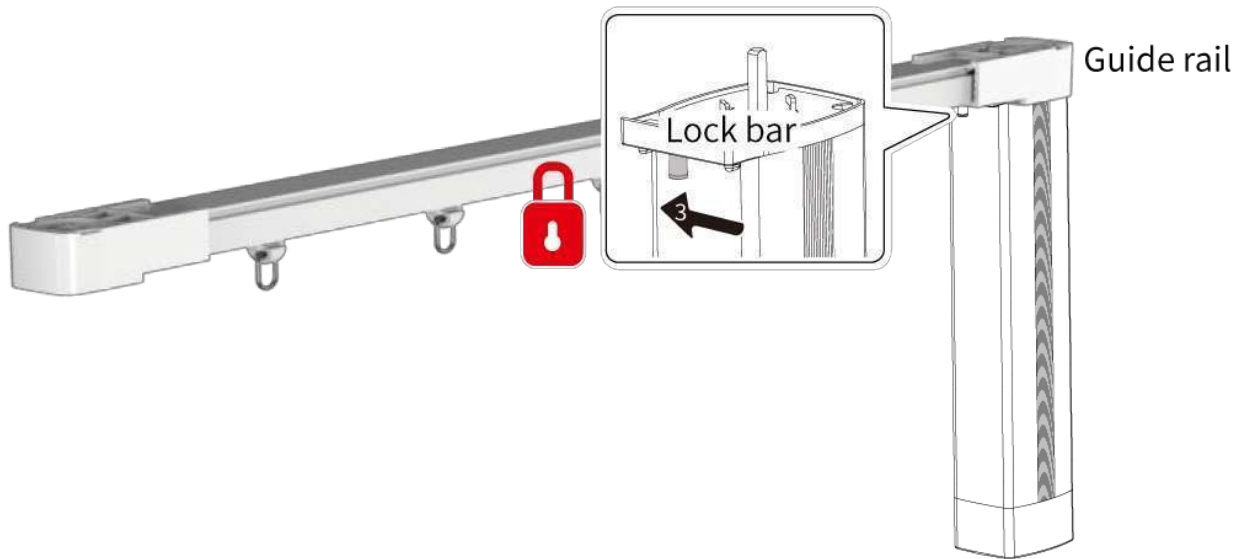

Figure 8

◆◆ Disassembly

◆◆ Operation

The device is configured with one programming button and indicator, as described below.

Note: All operation and settings described as below should be carried out when the device is running normally.

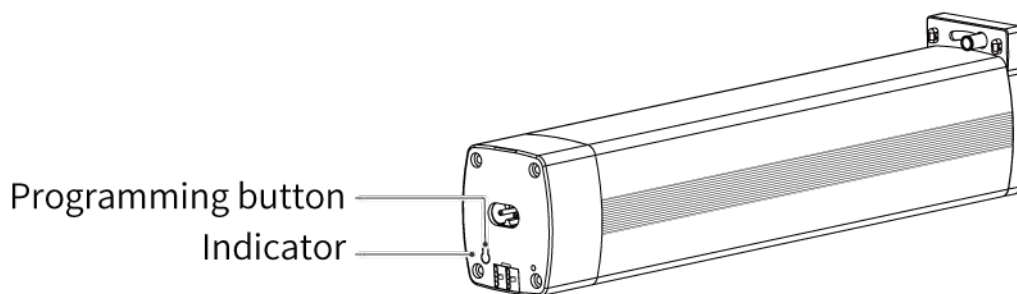

Figure 9

1. Basic Operation

1.1. Switch Power-on to Quick Start

Operation	Status of Indicator
Connect the device to power supply, then it starts running normally.	Red light is on then off.

1.2. Test Motor Travel

Operation	Status of Motor
Reconnect the device to power supply. When it restarts, pull the curtain cloth gently towards any direction.	Curtain motor will be activated to work and automatically complete the preset travel.

1.3. Control Curtain Cloth

Function	Operation
Open / close / stop / open or close at specific percentage	Users can achieve these remote control through smart panels, remote controllers, mobile APP.
Touch start	The device supports "Touch Start" by default, which can be enabled or disabled through commissioning software or the remote controller used. "Touch Start" enabled: When users gently pull the curtain cloth, curtain motor will be activated to work and automatically travel towards that pulling direction. "Touch Start" disabled: It requires users to manually operate the curtain cloth.
Obstruction detection	When curtain cloth or motor encounters obstacles, in order to avoid damage to the motor or obstacles, the motor will automatically stop running then modify its travel limit. Tips: If users need to adjust the motor travel limit, please remove those obstacles then erase travel limit (see Section 2.3. Erase Travel Limit). Afterwards, users can proceed re-setting and testing motor travel.

2. Advanced Settings

2.1. Programming Mode

Operation	Status of Indicator
Short press programming button once	Red light is on.

2.2. Set Motor Direction

Tips: Motor direction can be set by the Engineering Tool Software (ETS) or programming button. In this section, it only gives information about the latter.

Operation	Status of Indicator	Status of Motor	Remark
Step 1: Short press programming button once	Red light is on.	/	
Step 2: Short press programming button once again.	Red light flashes slowly.	/	

Step 3: Long press programming button for 3s.	Red light is on.	/	
Step 4: Long press programming button for 3s again.	Red light flashes then off.	After successfully set, the motor rotates once.	If no operation on programming button within 15s, it will exit setting automatically.

2.3. Erase Trave Limit

Operation	Status of Indicator	Status of Motor	Remark
Long press programming button for 5s, then immediately release until the indicator is flashing red.	Red light is on then flashing.	After successfully set, the motor rotates once.	

2.4. Update Firmware

Function	Operation	Status of Indicator	Status of Motor	Remark
On-line update	Upgrade device firmware through the Assistant Software.	Red light flashes.	/	
Manually update	Press programming button, and simultaneously connect the device to power supply. At this moment, [Manually Update] can be enabled. Next, proceed firmware updating through the Assistant Software.	Red light flashes.	/	

2.5. Learning Codes in Remote Controller

There are two options for pairing the device with remote controller, as described below. Regarding operations about further learning codes, please refer to the datasheet of the remote controller used.

Inside the remote controller used, users will see each side of the battery compartment has a channel setting button (see Figure 10), which is used for pairing the remote controller and the corresponding motor, then receiving and processing further learning codes. provided as below is for reference purposes only, and the actual remote controller may differ.

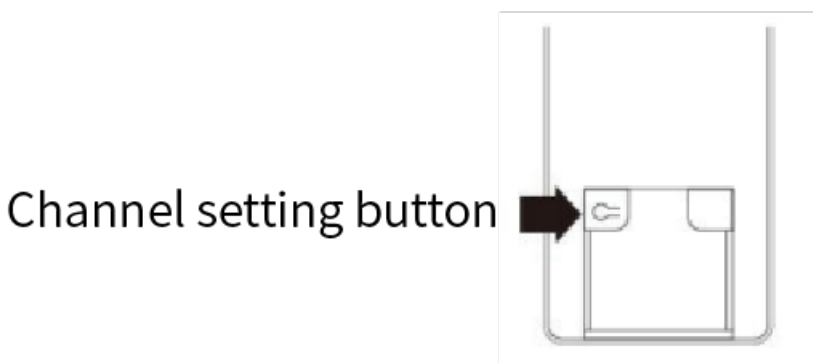

Figure 10
Battery Compartment of a Remote Controller

Function	Operation	Status of Indicator	Status of Motor	Remark
Option 1: Pairing by programming button	Step 1: Short press programming button, then release until the indicator is red. At this moment, the device is entering the status of learning code.	Red light is on.	/	
	Step 2: Press the channel setting button on the remote controller (see Figure 10).	Red light flashes then off.	After successfully set, the motor rotates once.	
Option 2: Pairing by switching power-on	Step 1: Switch the device power off then on. At this moment, the device is entering the status of learning code.	Red light is on.	/	
	Step 2: Press the channel setting button on the remote controller in 10 seconds (see Figure 10).	Red light flashes then off.	After successfully set, the motor rotates once.	

2.6. Erase Codes in Remote Controller

Operation	Status of Indicator	Status of Motor	Remark
Long press programming button for 10s	Red light is on then flashing, and then off	After successfully set, the motor rotates twice.	

2.7. Other

Status of Indicator	Status of Motor	Remark
Blue light flashes slowly.	The device is abnormal. Please check whether the 220V power supply is connected properly.	

◆◆ Packing List

- Curtain Motor*1
- Terminal block*1
- Power cable*1
- QR code card*1

Note: After unpacking, please check if the product and the parts are complete.

◆◆ Legal Statemen

HDL has all the intellectual property rights to this document and contents thereof. Reproduction or distribution for third parties are prohibited without written authorization from HDL. Any infringement of HDL's intellectual property rights will be investigated the legal liability.

The contents of this document will be updated as the updates of product versions or other reasons. Unless otherwise agreed upon, this document is to be used as a guidance only. All the statements, information and recommendations in this document makes no warranty expressed or implied.

© 2023 HDL Automation Co., Ltd. All rights reserved.

Update History

The form below contains the information of every update. The latest version contains all the updates of all former versions.

Version	Update Information	Date
V1.0	Initial release	March 25, 2024

◆◆ Technical Support

E-mail: hdltickets@hdlautomation.com

Website: <https://www.hdlautomation.com>