

Occupancy Plus Sensor

Instruction Manual



MSMW24-KT.11

Before using this product, please read this manual carefully and keep it properly!

Document Version: C

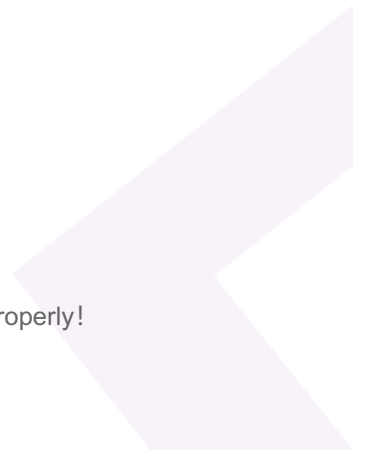

◆◆ Overview

Occupancy Plus Sensor (hereinafter referred to as the "product" or "device") is a KNX protocol human presence detection sensor that can accurately detect the human presence status in scenes such as movement and static breathing. Adopting 24GHz millimeter wave radar technology and advanced human detection algorithm, it integrates illumination module, temperature detection module, and 2 dry contact input interfaces. It can be flush mounted, meeting the needs of human presence detection and intelligent device linkage in home, public buildings, hotels and other scenes.

Key Functions:

- Human presence detection: 24GHz millimeter wave radar technology, accurate and high sensitivity for detecting human motion and breath.
- Illuminance monitoring: Real-time illuminance can be detected by the device, providing smart scene control in accordance with actual illuminance.
- Temperature monitoring: Built-in temperature sensor for monitoring real-time environment status.
- Dry contact input: Supports 2 dry contact inputs for logical judgment
- Easy lighting control: supports controlling 1 lighting device, supports automatic and semi-automatic control, and controls switches based on environmental illumination.
- Easy HVAC control: Supports controlling 1 HVAC device, with HVAC on/off delay function.
- Constant brightness control: Supports one constant brightness automatic adjustment function module, which automatically senses environmental brightness and adjusts dimming values.
- 2 working modes: Single mode and master/slave mode. One master sensor can have 15 slave sensors, providing wide range of detection.
- Logic settings: 5 independent logic modules, each of which can control 10 targets, including switches, dimming, alarm devices, etc.
- Logical input conditions: human body detection status, illuminance value, temperature value, dry contact input, external message, threshold comparator.
- 3 logical relations: AND, OR, XOR.
- Control types: switch control, absolute dimming control, curtain control, alarm control, percentage control, sequence control, scene control, string (14 byte) control, threshold control and logical combination control.
- External messages can alter the validity of logic.
- Support KNX Data Secure

◆◆ Appearance

This device is available in surface-mounted and flush-mounted installation styles. By default, the device is delivered in a flush-

mounted form as shown in Figures 1 & 2.

Note: When installing, make sure to select the suitable bracket based on your specific requirements, as shown in Figures 3 & 4.

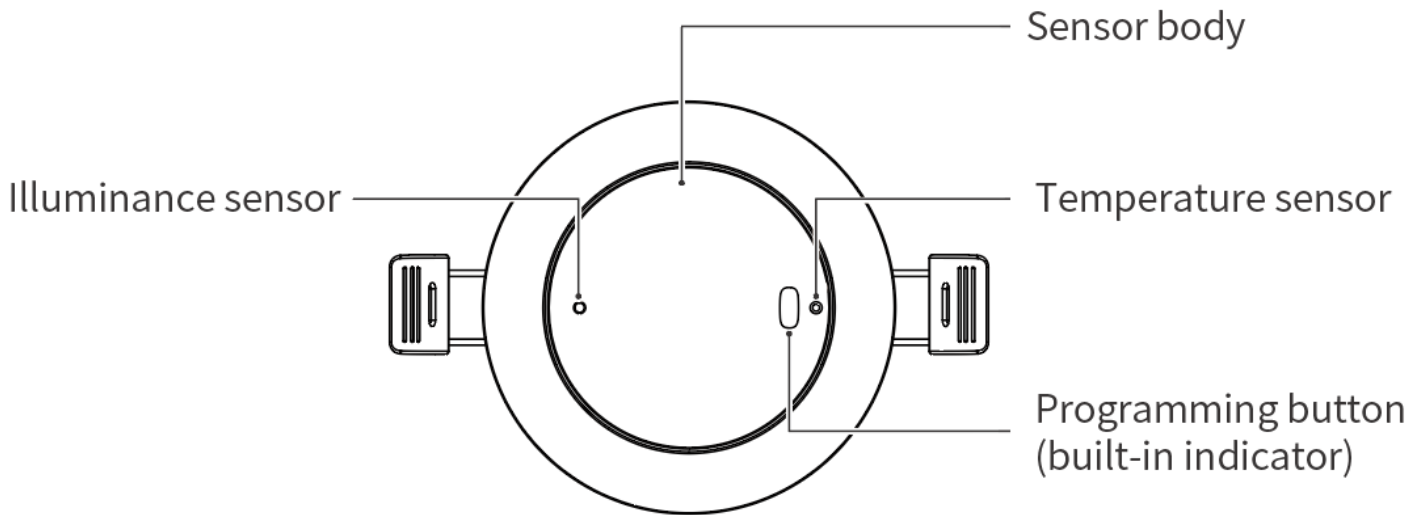

Figure 1

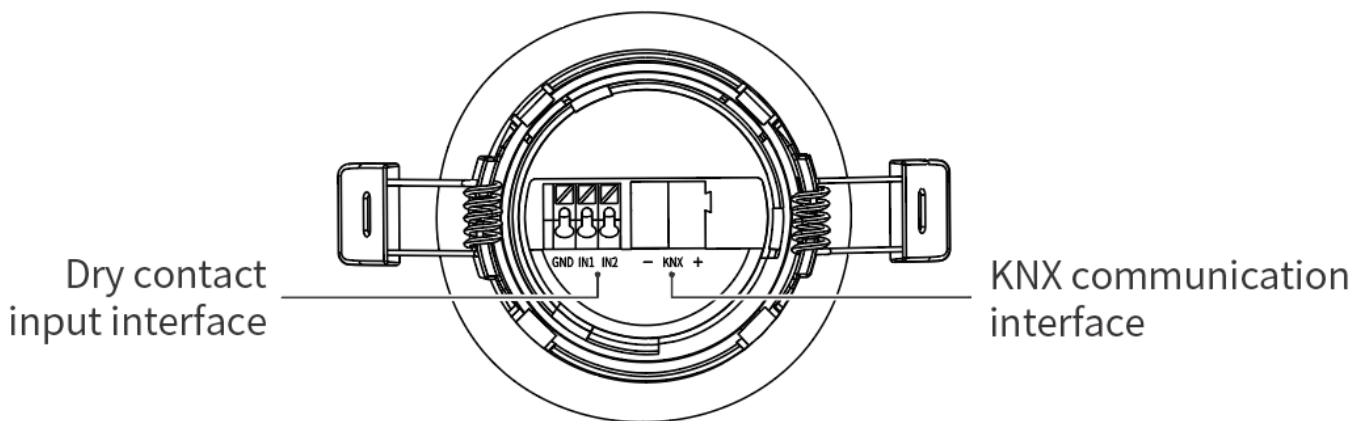

Figure 2

- Installation by the bracket (for flush-mounted)

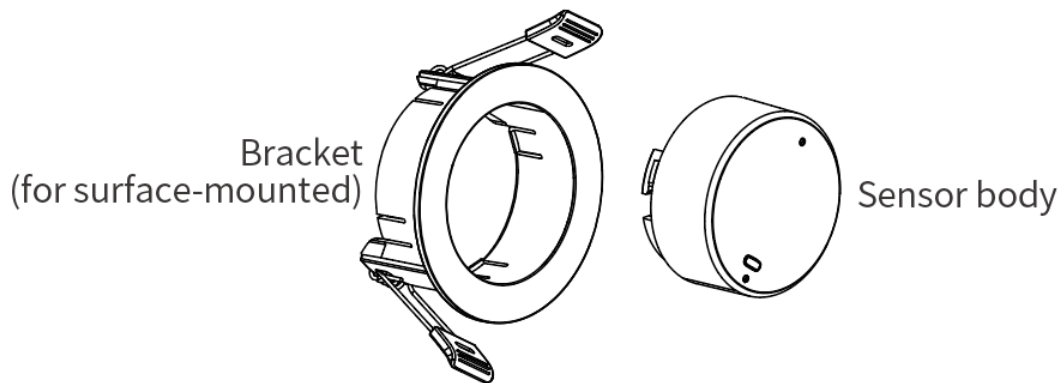

Figure 3

- Installation by the bottom cap (for surface-mounted)

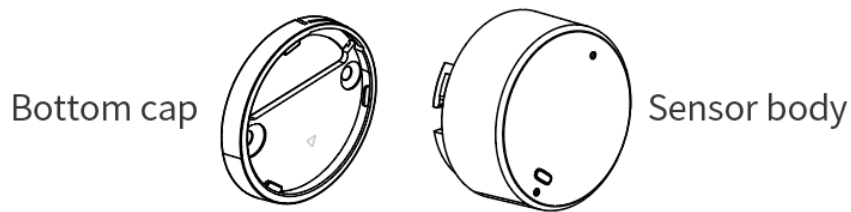

Figure 4

◆◆ Technical Data

Item	Parameter
Rated voltage	30V DC
Rated current	50mA/30V DC
Input voltage	21 - 30V DC
Dry contact	2 dry contacts
Communication protocol	KNX
Cable diameter of KNX terminal	0.6 - 0.8mm
Detection frequency for micro motion	24GHz-24.25GHz
Detection range for micro motion (radius)	0.5-4m, adjustable (Note: Installation height is 3m.)
Detection range for illuminance	0-1200Lux
Detection range for temperature	-20°C~60°C
Working temperature	-5°C ~ 45°C
Working relative humidity	≤90%RH, non-condensed
Storage temperature	-20°C ~ 60°C
Storage relative humidity	≤93%RH

◆◆ Specifications

Item	Parameter
Dimensions of installation for surface-mounted	Φ66 x 34.6mm (Opening size: Φ60mm, see Figure 5 & 6)
Dimensions of installation for flush-mounted	Φ48.5 x 27.5mm (see Figure 7 - 9)

Housing material	ABS
Installation	Flush-mounted (Opening size: $\Phi 60\text{mm}$, see Figure 13) Surface-mounted (see Figure 14)
Installation height (recommended)	2.5 - 3.5m
IP degree (compliant with EN 60529)	IP20

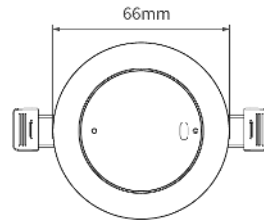
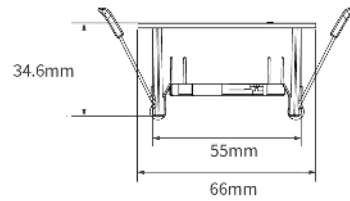

Figure 5



Note: Opening size is $\Phi 60\text{mm}$.

Figure 6

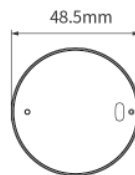

Figure 7

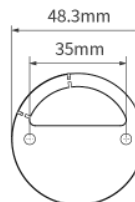

Figure 8

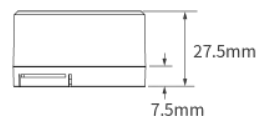

Figure 9

◆◆ Safety Precaution

Danger:

Please do not privately disassemble or replace any parts of the product. Otherwise, it may cause mechanical fault, electric shock, fire or personal injuries.

Warning:

- The installation and testing for the product must be carried out by HDL Automation Co., Ltd. (hereinafter referred to as HDL) or its appointed service agencies. The electric construction shall comply with local laws and safety regulations.
- HDL will not be responsible for any consequence caused by the inexpert or faulty installation and wiring methods, which are not in accordance with the instructions contained in this datasheet.
- Please contact HDL after-sales departments or our designated service agencies for your maintenance service. Product failures caused by private disassembly are not subject to the warranty.

Caution:

- Before performing any installation or disassembly procedures, any maintenance or cleaning procedures on the device, it is crucial to disconnect the device from all voltage sources. This step is necessary to ensure the safety of the technician and prevent any potential damage to the device.
- Do not use corrosive liquid to wipe the device body, especially the interface, so to avoid damage to the device.
- Do not wipe the device with a damp cloth.
- Prior to performing maintenance or cleaning on the device, disconnect the device from all voltage sources, to avoid electric leakage and electric shock.
- Bus cable: KNX cable.
- For KNX connection, a hand-in-hand connection is recommended.
- After all of the cables are terminated, check for correct and good terminations.
- This device's 2-channel dry contact only supports input function. Do not connect the ground wire of other power sources to the GND interface of the device's dry contact to avoid communication abnormalities.

◆◆ Wiring

Tips: For KNX connection, a hand-in-hand connection is recommended.

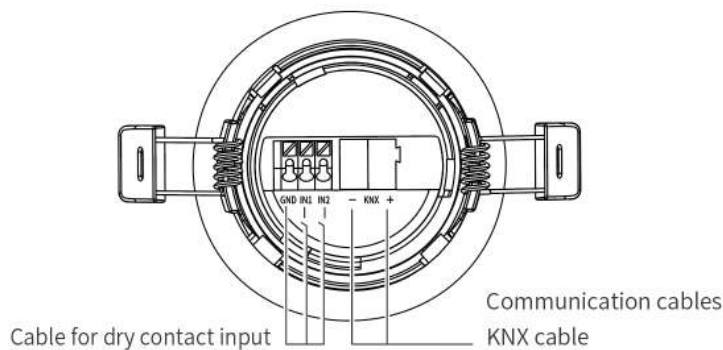

Figure 10

KNX Cable Guide:

KNX	KNX cable
-	Black
+	Red

◆◆ Installation

1. Detection range

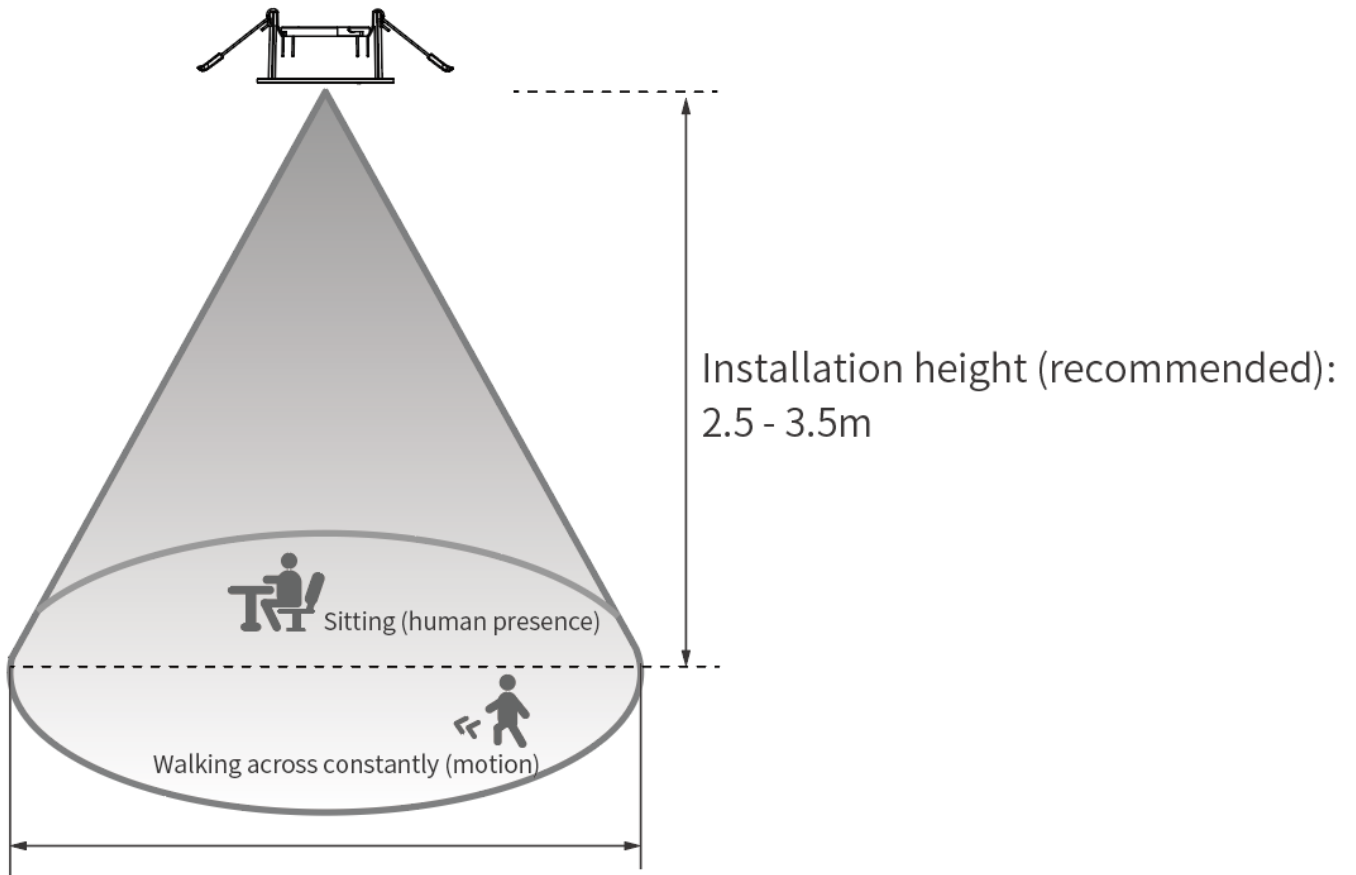

Detection range for human presence / motion (in terms of diameter):
 $\Phi 8\text{m}$ (installation height: 3m)

Figure 11

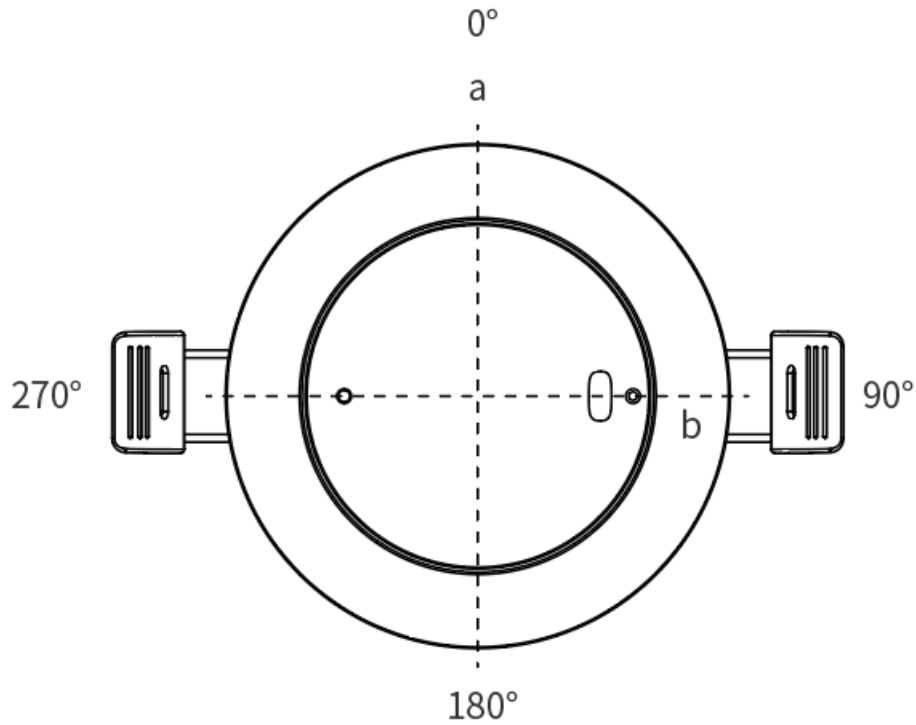

Figure 12

When the installation height is 3m and the sensitivity level is high:

Angle	Maximum detection distance for movement	Maximum detection distance for presence
0°	4.5m	4.5m
90°	4m	4m
180°	3.5m	3.7m
270°	4m	4m

Note:

- Sensors can be set with different sensitivity levels and detection ranges.
- The detection distance varies in different environments and installation heights, and there may be an error of $\pm 0.5\text{m}$; The data is laboratory data for reference only.
- The detection range of the device is oval-like, as shown in Figure 12, Edge(a) detects the long-axis range of the oval, Edge(b) detects the short-axis range of the oval, and the length of each edge varies according to different spaces and environments. The detection range can be adjusted by adjusting the installation direction of the device.
- The device can only be installed indoors. The installation site must be far away from air outlet and heat source such as air conditioner and fan, and avoid installation near large area metal objects.
- Millimeter wave band electromagnetic wave has certain penetration characteristics for non-metallic materials, which may penetrate common glass, wood, screens and thin partition walls, and can detect moving objects behind shielding objects, but can not penetrate thick load-bearing walls, metal doors and so on.

- If the human chest and abdominal cavity are not facing the sensor directly, are blocked by tables and chairs, are in a sleep state, or are in the middle or edge of the detection range, there may be a decrease in the device's performance.
- Please keep the device away from large metal equipment, pipes, air conditioning outlets, exhaust vents, smoke exhaust machines and other scenes, so as not to affect the detection effect of equipment vibration.
- Please make sure that the device is installed securely, otherwise the device itself may move under the wind or vibration, which may lead to false alarm of human presence.
- The installation antenna face of millimeter wave radar products should not be shielded (such as chandeliers, pipes, etc.), otherwise it may affect the normal operation of millimeter wave radar products.
- The detection range data (shown in Figure 11) are for reference only and come from internal laboratory tests. There may be differences in results depending on installation environment, human presence and sensitivity.

2. Installation

The device can be mounted by the bracket (for flush-mounted) or by the bottom cap (for surface-mounted), please proceed installation as the actual needs.

Note:

- The device can only be installed indoors. The installation site must be far away from air outlet and heat source such as air conditioner and fan, and avoid installation near large area metal objects.
- Before performing any installation procedures, any maintenance or cleaning procedures on the device, it is crucial to disconnect the device from all voltage sources. This step is necessary to ensure the safety of the technician and prevent any potential damage to the device.

2.1. Installation by the bracket (for flush-mounted)

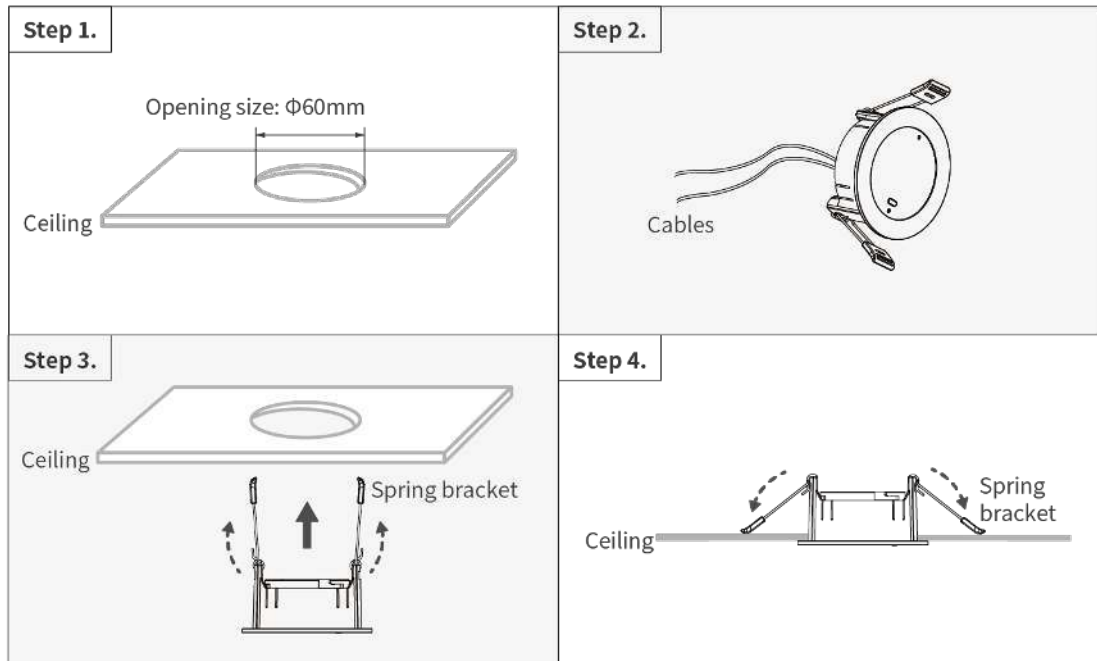

Figure 13

Step 1. Make a proper opening on the ceiling.

Note: The opening size for installation is $\Phi 60\text{mm}$; The installation height should be 2.5 - 3.5m.

Step 2. Get the necessary cables ready in the ceiling.

Step 3. Flip up the spring bracket and push the device into the opening on the ceiling.

Step 4. Flip down the spring bracket to fix the device and ensure the device is tightly attached to the ceiling.

2.2. Installation by the bottom cap (for surface-mounted)

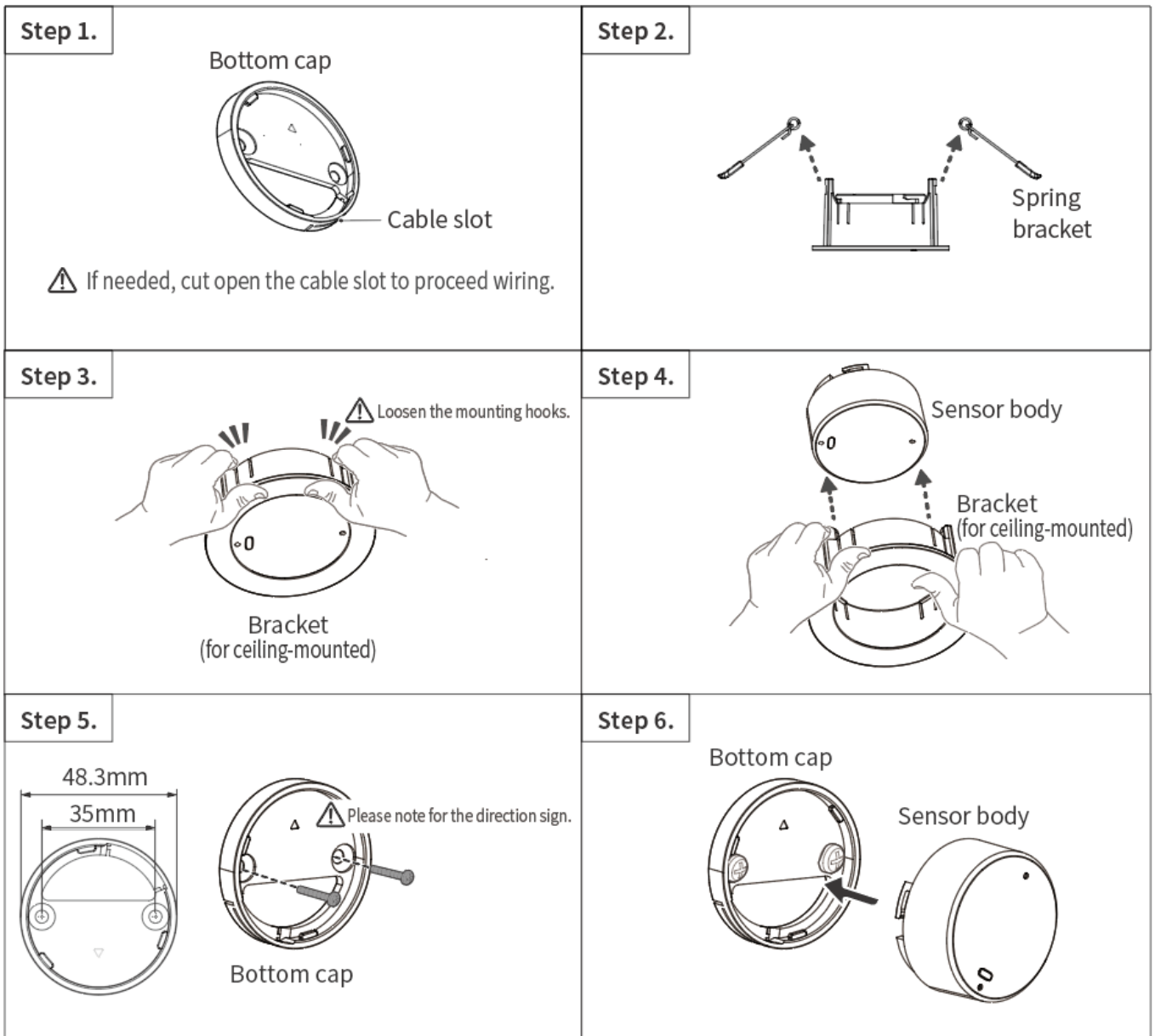

Figure 14

Step 1. Get the necessary cables ready in the ceiling. If needed, cut open the cable slot to proceed wiring.

Note: The installation height should be 2.5 - 3.5m.

Step 2. Remove the spring brackets.

Step 3. Loosen the mounting hooks.

Step 4. Push then remove the sensor body from the bracket (for flush-mounted).

Step 5. Fix the bottom cap with screws.

Note: To select suitable installation site, please refer to dimensions of the bottom cap, as well as the direction sign.

Step 6. Rotate then assemble the sensor body onto the bottom cap. Please ensure the device is tightly attached to installation site.

◆◆ Disassembly

Warning: Before performing any disassembly procedures on the device, it is crucial to disconnect the device from all voltage sources. This step is necessary to ensure the safety of the technician and prevent any potential damage to the device.

To remove the device, please refer to the reverse steps in the section Installation.

◆◆ Operation

The device is configured with one programming button and one indicator, as described below.

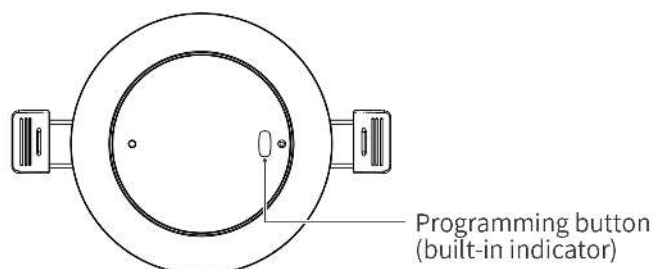

Figure 15

• Indicator

Tips: It is supported to turn off the indicator through commissioning software.

Indicator status	Indicator status description
Make the device power-on, then the indicator slowly flashes.	Device initializing...please wait 5 seconds
Green light is on.	Human presence detected
Green light flashes once at an interval of 2s.	Human presence not detected
Red light is on.	Programming mode, time-out: 10 min
Red light flashes.	Device locating mode / Device upgrading...
Off	Device is power-off. / The indicator is turned off. / Detection is disabled.
Red light and green light flash alternately.	Device error, unable to function normally

• Programming button

Function	Operation	Indicator Status
Restore factory setting	Long press for 10s	Red light is on and then flashes green.
Encoding Mode	Short press once	Red light is on.

◆◆ Packing List

- Occupancy Plus Sensor (with the bracket for flush-mounted by default)*1

- Bottom cap (for surface-mounted)*1
- Screw (M3.5*40)*2

Note: After unpacking, please check if the product and the parts are complete.

◆◆ Copyright Statement

HDL has all the intellectual property rights to this document and contents thereof. Reproduction or distribution for third parties are prohibited without written authorization from HDL. Any infringement of HDL's intellectual property rights will be investigated the legal liability.

The contents of this document will be updated as the updates of product versions or other reasons. Unless otherwise agreed upon, this document is to be used as a guidance only. All the statements, information and recommendations in this document makes no warranty expressed or implied.

© 2025 HDL Automation Co., Ltd. All rights reserved.

Update History:

The form below contains the information of every update. The latest version contains all the updates of all former versions.

Version	Update Information	Date
V1.0	Initial release	March 11, 2025

◆◆ Technical Support

E-mail: hdltickets@hdlautomation.com

Website: <https://www.hdlautomation.com>