

KNX<->RS232/RS485 Converter

Datasheet



M/KRS232/485.1



Please scan the QR code above to check the latest version of datasheet!

Before using this product, please read this datasheet carefully and keep it properly!

Document Version: C

◆◆ Overview

KNX<->RS232/RS485 Converter is used for bidirectional data exchange between KNX and RS232, KNX and RS485.

Key function:

- 3 working modes: String mode, Hexadecimal mode, Data mode
- RS232 interface work in all baud rates: 600,1200, 2400, 4800, 9600, 19200, 38400, 57600, 115200bps. Users can choose baud rates according to their requirements.
- Gateway between KNX and RS232 or RS485 and KNX, only one communication method can be selected from RS232 and RS485 at the same time.
- Gateway between KNX and RS232: RS232 (string mode or hexadecimal mode, data mode) <-> KNX/EIB.
- Gateway between KNX and RS485: RS485 (string mode or hexadecimal mode, data mode) <-> KNX/EIB.
- Supports up to 100 control targets
- Up to 200 characters for each target
- 24 sequences supported

◆◆ Appearance

The parts on the figure are:

1. RS485 connector
2. RS232 connector
3. Programming button & LED indicator

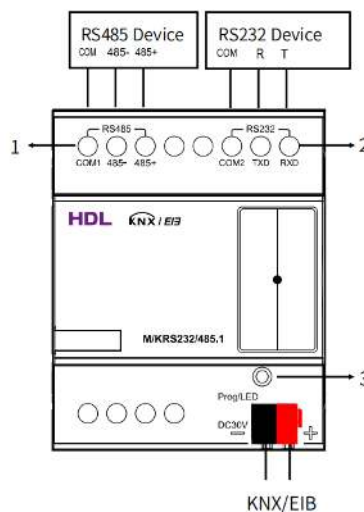

Figure 1

◆◆ Technical Data

Basic Parameters	
Rated voltage	30V DC
Rated current	20mA/30V DC
Communication	KNX, RS232, RS485
Data bit	7 bits, 8 bits, 9 bits
Stop bit	0.5 bit, 1 bit, 1.5 bits, 2 bits
Cable diameter of KNX terminal	0.6 - 0.8mm
External Environment	
Working temperature	-5°C~45°C
Working relative humidity	≤90%
Storage temperature	-20°C~60°C
Storage relative humidity	≤93%
Specifications	
Dimensions	72mm×90mm×64mm
Net weight	111g
Housing material	Flame retardant nylon
Installation	35mm DIN rail installation
Protection rating (Compliant with EN 60529)	IP20
Approved	CE, RoHS, KNX

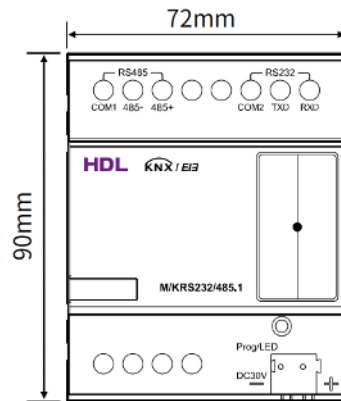

Figure 2. Dimensions - Front View

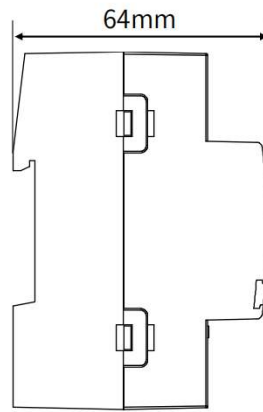

Figure 3. Dimensions - Side View

◆◆ Safety Precaution

Warning:

- The installation and testing for the product must be carried out by HDL Automation Co., Ltd. or its appointed service agencies. The electric construction shall comply with local laws and safety regulations.
- The device should be installed with Din rail in DB box. HDL will not be responsible for any consequence caused by the inexpert or faulty installation and wiring methods, which are not in accordance with the instructions contained in this operating instruction.
- Please do not privately disassemble or replace any parts of the product. Otherwise, it may cause mechanical fault, electric shock, fire or personal injuries.
- Please contact our after-sales departments or our designated service agencies for your maintenance service. Product failures caused by private disassembly are not subject to this warranty.

Note:

- Installation - Distribution box
- Programming - The device is compliant with the KNX standard and the parameters are set by the Engineering Tool Software (ETS).
- KNX Bus voltage - 21~30V DC, no AC power supply allowed
- Check connection - Re-tighten all connections after installation.
- Make sure the RS485 cable is in correct connection to the module connector 485+, 485-, COM1.
- Make sure the RS232 cable is in correct connection to the module connector RX,TX, COM2.

◆◆ Installation

Step 1. Fix the DIN rail with screws.



Figure 4

Step 2. Buckle the bottom cap of the KNX<->RS232/RS485 Converter on the edge of the DIN rail.

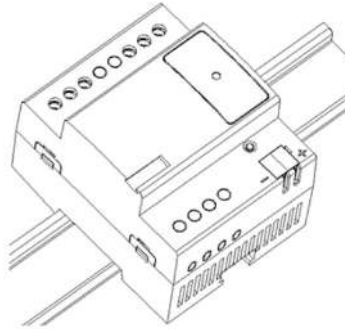

Figure 5

Step 3. Press the device on the DIN rail, slide it and fix it up until an appropriate position is adjusted.

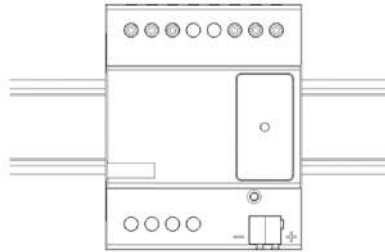

Figure 6

◆◆ Packing List

M/KRS232/485.1*1 / Label*5

◆◆ Copyright Statement

HDL has all the intellectual property rights to this document and contents thereof. Reproduction or distribution for third parties are prohibited without written authorization from HDL. Any infringement of HDL's intellectual property rights will be investigated the legal liability.

The contents of this document will be updated as the updates of product versions or other reasons. Unless otherwise agreed upon, this document is to be used as a guidance only. All the statements, information and recommendations in this document makes no warranty expressed or implied.

© 2025 HDL Automation Co., Ltd. All rights reserved.

Update History:

The form below contains the information of every update. The latest version contains all the updates of all former versions.

Version	Update Information	Date
V1.0	Initial release	July 25, 2025

◆◆ Technical Support

E-mail: hdltickets@hdlautomation.com

Website: <https://www.hdlautomation.com>