

# Tile Series Thermostat 2.1

## Datasheet



MPHT-6B-KT.18



Please scan the QR code above to check the latest version of datasheet!

Before using this product, please read this datasheet carefully and keep it properly!

Document Version: C

## ◆◆ Overview

**Tile Series Thermostat 2.1** (hereafter referred to as the “product” or “device”, model No.: MPHT-6B-KT.18), has a segmented LCD screen and mechanical buttons, each button supporting laser engraving, and it has air conditioning, floor heating, fresh air pages and mode, wind speed pages.

**Note:** The product complies with the KNX safety standards, providing a high level of communication security for the intelligent control system.

### Main functions:

- Built-in temperature and humidity sensor collects the temperature and humidity of the location of the device and displays it on the screen, supporting scene linkage with other devices of HDL system
- Human proximity sensor: When the human body approaches this device, the panel automatically lights up.
- Screen backlight brightness can be set on ETS6.
- RGB LED indication function: support customized button indicator brightness and colour configuration.
- HVAC control: air conditioning control (VRF), floor heating control, fresh air control.
- Button lock/unlock function
- Support KNX online upgrade

## ◆◆ Appearance

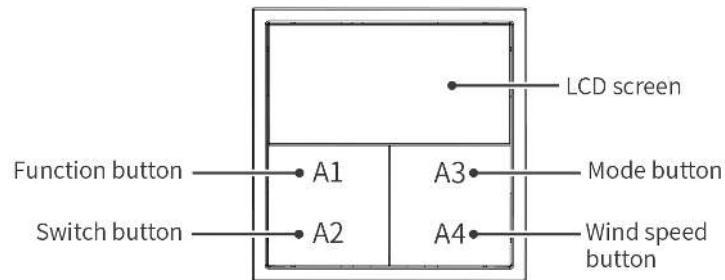

Figure 1

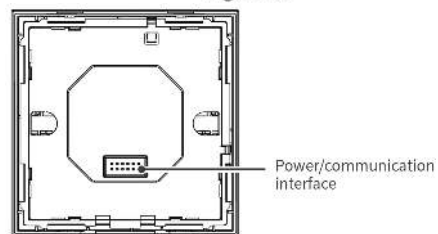

Figure 2

## ◆◆ Technical Data

Item	Parameter
------	-----------

Rated voltage	5V DC
Rated current	170mA/5V DC
Rated voltage(With power interface)	KNX bus supply: 30V DC Auxiliary power supply: 24V DC
Rated current(With power interface)	KNX bus supply: 10mA/30V DC Auxiliary power supply: 45mA/24V DC
Communication protocol	KNX
Working temperature	-5°C~45°C
Working relative humidity	≤90%RH, non-condensed
Storage temperature	-20°C~60°C
Storage relative humidity	≤93%

## ◆◆ Specifications

Item	Parameter
Dimensions (W X H X D)	86×86×10.5(mm)
Net weight	PC: 85g; Metal: 87.5g
Housing material	PC/Aluminum alloy
Installation	Wall box (Figure 5, 6, 7)
IP degree (compliant with EN 60529)	IP20

**Note:** The product complies with the KNX safety standards, providing a high level of communication security for the intelligent control system.

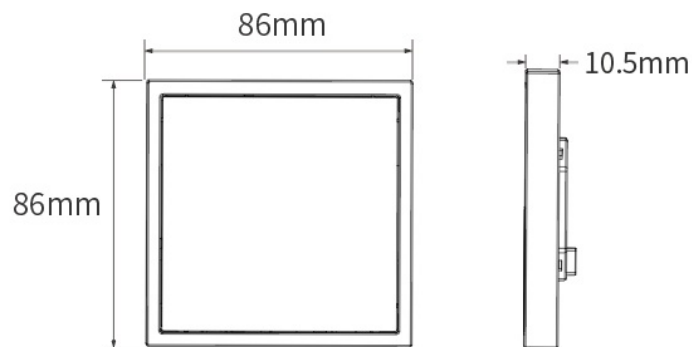

Figure 3

## ◆◆ Safety Precaution

**Danger:**

Please do not privately disassemble or replace any parts of the product. Otherwise, it may cause mechanical fault, electric shock, fire or personal injuries.

**Warning:**

- Installation and commissioning of this equipment must be carried out by us or by an organization appointed by us. The planning and construction of the electrical connection of this equipment must comply with the relevant local safety standards and regulations.
- Any consequences caused by failure to install and wire according to this instruction are not related to our company.
- Please refer all maintenance work to our after-sales department or designated organization, the warranty of this product does not apply to the failure caused by the user's disassembly of the product.
- It is not allowed to change the usage scenario or conditions, expand the transmission frequency range, increase the transmission power (including installing additional RF power amplifiers), or change the transmission antenna without authorization.
- No harmful interference shall be caused to other legitimate radio stations, nor shall protection against harmful interference be proposed.
- If harmful interference occurs to other legitimate radio stations, the use should be immediately stopped and measures should be taken to eliminate the interference before continuing to use.

**Caution:**

- Before performing any installation or disassembly procedures, any maintenance or cleaning procedures on the device, it is crucial to disconnect the device from all voltage sources. This step is necessary to ensure the safety of the technician and prevent any potential damage to the device.
- It is a **MUST** to install the device with wall box.
- Do not use corrosive liquid to wipe the device body, especially the interface, so to avoid damage to the device.
- Prior to performing maintenance or cleaning on the device, disconnect the device from all voltage sources, to avoid electric leakage and electric shock.

## ◆◆ Wiring

**Note:**

- The device can be used with Panel Power Interface With Auxiliary Power Supply EU.
- Please wire according to HDL standards:KNX+, KNX-, GND and +24V.

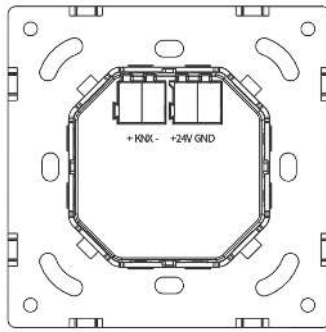

Panel Power Interface With  
Auxiliary Power Supply EU(KNX)

Figure 4

## ◆◆ Installation

- **Warning:** Before installation, please cut off the power supply, it is strictly prohibited to operate with electricity.

**Step 1.** Install the wall box (the depth of wall box should not be less than 45mm) on the wall and lead out KNX cable . Connect the cables, and pay attention to safe and reliable wiring.

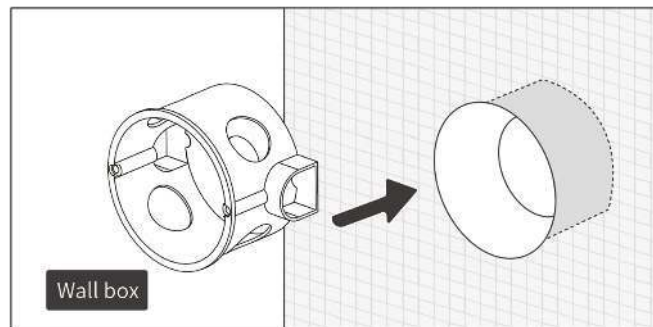

Figure 4

**Step 2.** Insert the power interface into the bracket.

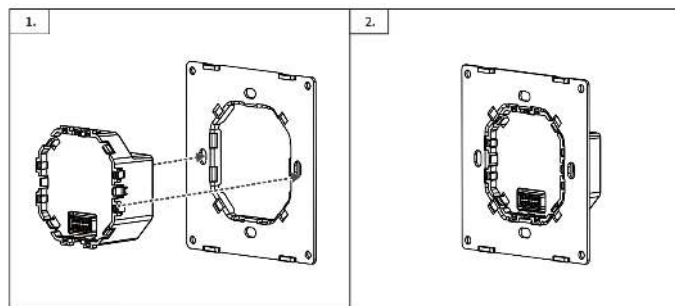

Figure 5

**Step 3.** Use screws to fix the power interface in the wall box.

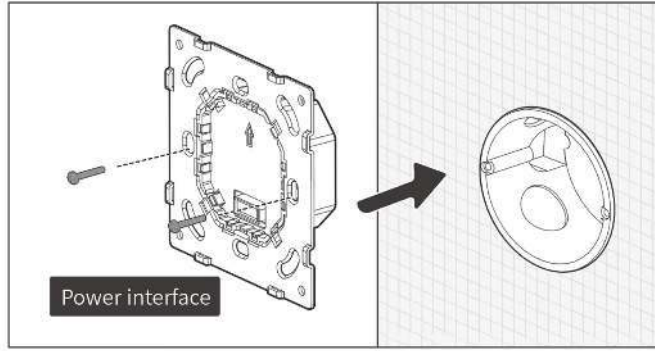

Figure 6

**Step 4:** Assemble the panel onto the bracket.

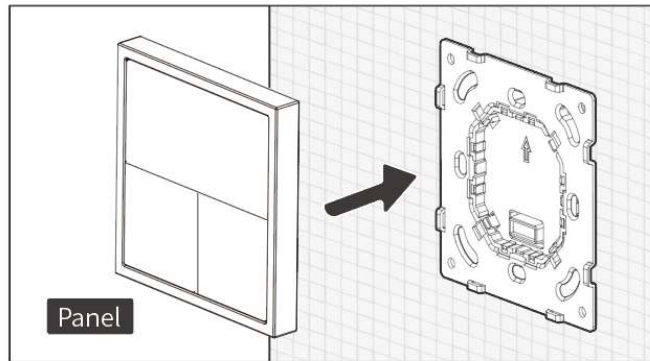
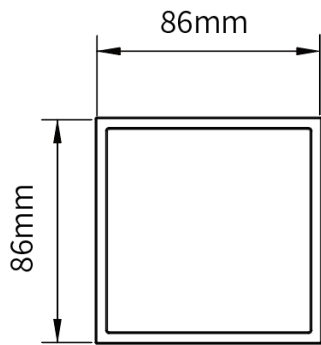

Figure 7

**Multi-gang installation:**

- Supports horizontal and vertical installation;
- Horizontal installation supports up to 4 rows;
- Vertical installation supports up to 4 columns.

Frame type	Installation direction	Gang number	Size
PC	Horizontal/Vertical	1	86*86*10.5(mm)
		2	172*86*10.5(mm)
		3	258*86*10.5(mm)
		4	344*86*10.5(mm)
Metal	Horizontal/Vertical	1	86*86*10.5(mm)
		2	172*86*10.5(mm)
		3	258*86*10.5(mm)
		4	344*86*10.5(mm)



Single-gang frame

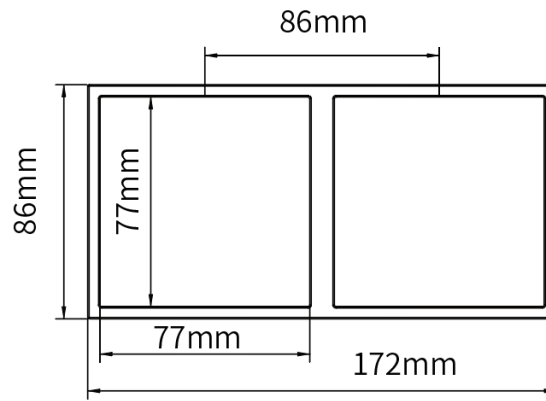

Two-gang frame

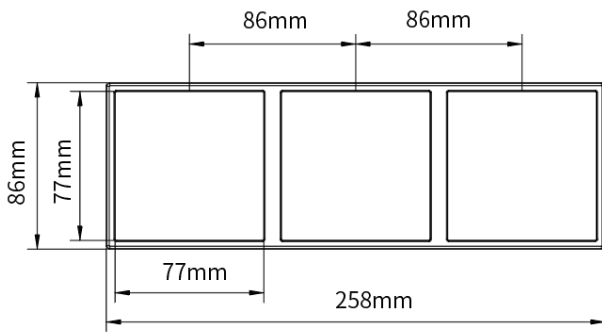

Three-gang frame

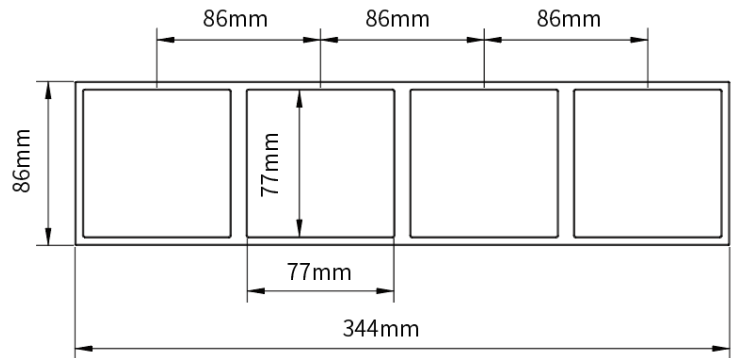

Four-gang frame

## ◆◆ Disassembly

**Warning:** Before performing any disassembly procedures on the device, it is crucial to disconnect the device from all voltage sources. This step is necessary to ensure the safety of the technician and prevent any potential damage to the device.

**Step 1.** It is recommended to use a screwdriver to loosen the screw at the bottom of the panel, then loosen the panel.

**Step 2.** To remove the panel and power interface, please refer to the reverse steps in the section Installation.

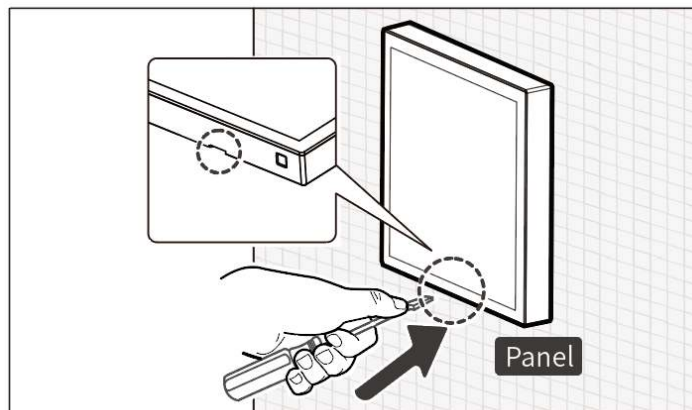

Figure 7

## ◆◆ Operation

**1. Programming mode:** Long press any button for 15 seconds, all the backlights will turn blue and flash slowly, and the programming mode is on (When in programming mode, support for downloading the product database is provided.)

### **2. Panel lock/unlock:**

- Manual lock: short press A1 and A4 button at the same time for 5 seconds, the indicator light flashes blue (power off and re-power on, the panel is still locked)
- Auto-lock: users can configure the auto-lock function in the ETS, set the time for locking, and the panel will be locked automatically after a certain period of time.
- Panel unlock: press A1 and A4 button at the same time for 5 seconds, the panel will be unlocked.

**Note:** Unlocking must be done manually.

**3. Customize the colour of the button indicator:** support colour customization through the commissioning software (please refer to the commissioning instructions for details).

**4. Proximity sensor function setting:** support setting of sensing distance and time of the sensor waking up panel indicator through the commissioning software (please refer to the commissioning instructions for details).

Device	Temperature +/- button	Function button A1	Switch button A2	Mode button A3	Wind speed button A4
Air conditioning (VRF)	Change temperature	Short press to loop pages (air conditioning → floor heating → fresh air)	Turn on/off AC page	Short press to switch control mode	Short press to change wind speed
Floor heating	Change temperature	Short press to loop pages (air conditioning → floor heating → fresh air)	Turn on/off floor heating page	Short press to switch control mode	/
Fresh air	/	Short press to loop pages (air conditioning → floor heating → fresh air)	Turn on/off fresh air page	/	Short press to change wind speed

## ◆◆ Packing List

- Panel\*1

## ◆◆ Warranty

Warranty period (five years from the date of invoice), if the product fails in normal use, the user can go to the nearest authorized institution with a valid warranty card to obtain free maintenance.

In the following cases, HDL regards the user as giving up the relevant services promised under the warranty and the user shall bear the corresponding responsibility and shall not be entitled to the free warranty:

- Failure of the device caused by force majeure factors.
- The user has placed the device in a transportation or use environment that does not comply with the statements in the product instructions or technical manuals.
- Unauthorized disassembly of the product by the user.
- Promises not made officially by HDL to the user that are beyond the scope of the warranty are the responsibility of the promisor.

HDL reserves the right to update or change the product without prior notice to the user, please visit the HDL website for answers to your questions and the latest product information.

The final interpretation right of the warranty regulations belongs to HDL.

## ◆◆ Copyright Statement

HDL has all the intellectual property rights to this document and contents thereof. Reproduction or distribution for third parties are prohibited without written authorization from HDL. Any infringement of HDL's intellectual property rights will be investigated the legal liability.

The contents of this document will be updated as the updates of product versions or other reasons. Unless otherwise agreed upon, this document is to be used as a guidance only. All the statements, information and recommendations in this document makes no warranty expressed or implied.

© 2025 HDL Automation Co., Ltd. All rights reserved.

### **Update History:**

The form below contains the information of every update. The latest version contains all the updates of all former versions.

<b>Version</b>	<b>Update Information</b>	<b>Date</b>
V1.0	Initial release	November 11, 2024
V1.1	Update wiring instructions	September 5, 2025
V1.2	Update overview and specifications	November 17, 2025

## ◆◆ Technical Support

E-mail: [hdltickets@hdlautomation.com](mailto:hdltickets@hdlautomation.com)

Website: <https://www.hdlautomation.com>