

Modern Series DLP Touch Panel US (See Figure 1) is a multi-function control panel for home automation with 8 control buttons, 2 page buttons and 4 shortcut buttons. 4 general pages, the display content of which can be modified via programming software according to users' preference, are for controlling lights and curtains, etc. and dedicated air conditioner page, floor heating page and background music page are available. The shortcut buttons can turn to certain page directly, which is convenient for users.

Functions

- Built-in temperature sensor and proximity sensor
- Multipage control, dedicated page for floor heating, air conditioning, music control
- Icon for buttons can be defined by user.
- Button combination and double button combination function available, button mutual exclusion available
- RGB button indicator and voice prompt are available.
- Adjustable LCD backlight
- Shortcut buttons are available.
- LCD screen wakes up automatically.
- Various key mode: Invalid, single on-off, single on, single off, combination on-off, combination on, combination off, double click/single on-off, double click/combination on-off, momentary, clock, short/long press, short press/long momentary press.
- Various key control types: Scene, Sequence, Timer switch, Universal switch, Single channel control, Broadcast scene, Broadcast channel, Curtain switch, GPRS control, Panel control, Security module, Music control.
- Panel control functions include: Panel lock, AC switch, AC cooling/ heating selection, Auto temperature setting, fan speed adjustment, AC mode setting, AC temperature adjustment, backlight switch, AC lock, backlight and status indicator luminance setting, floor heating temperature and mode control, etc.
- Update online via HDL Buspro is available.

Important Notes

- The panel should be installed on wall box.
- The panel should work in conjunction with the power interface.
- Buspro connection - hand-in-hand recommended.

Product Information

Dimensions - See Figure 2 - 5

A1. LCD screen: 29x84(mm). A part of icons can be customized by user via HDL Buspro Setup Tool.

A2. Button indicator: Indicates the status of the controlled target. When it is in on-status, the LED indicator shows the setting color for on-status; When it is in off-status off, the LED indicator shows the setting color for off-status. User can customize the color of status.

A3. Control button: To control targets, button sound available.

A4. Page button: To switch between different pages. Pages can be displayed or hidden via programming software.

A5. Shortcut button: Redirect to a certain page.

A6. Communication interface: HDL Buspro connector. It connects to panel power interface.

A7. Mounting slot: Connects to panel power interface.

A8. Split gap: Insert a slotted screwdriver to the split gap to separate the panel and power module.

Dimming: Long press the button for dimming when control types are set to scene, single-channel lighting on-off, and enable dimming.

Safety Precautions

- The installation and testing for the product must be carried out by HDL Automation Co., Ltd. or its appointed service agencies. The electric construction shall comply with local laws and safety regulations.
- The device should be installed in wall box. HDL will not be responsible for any consequence caused by the inexpert or faulty installation and wiring methods, which are not in accordance with the instructions contained in this operating instruction.
- Please do not privately disassemble or replace any parts of the product. Otherwise, it may cause mechanical fault, electric shock, fire or personal injuries.
- Please contact our after-sales departments or our designated service agencies for your maintenance service. Product failures caused by private disassembly are not subject to this warranty.

Package Contents

HDL-MPTL14.46-B*1 / Datasheet*1

HDL-MPTL14.46-B

Modern Series DLP Touch Panel US

Datasheet

Issued: February 18, 2022

File Edition: B



Figure 1. Modern Series DLP Touch Panel US

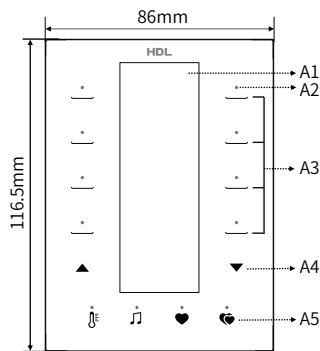

Figure 2. Regular

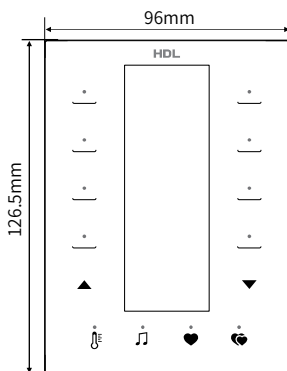

Figure 3. Larger

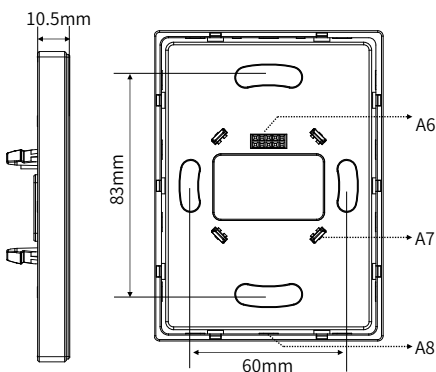
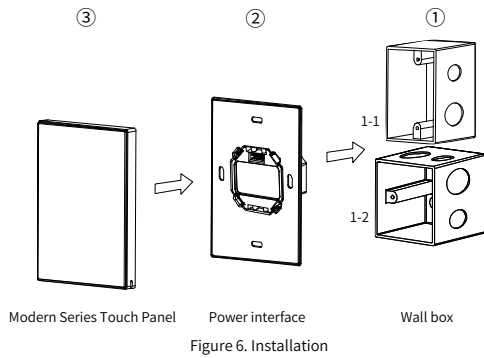

Figure 4

Figure 5

Figure 2 - 5. Dimensions



Technical Data

Basic Parameters

Working voltage	12~30V DC
Working current	45mA/24V DC
Communication	HDL Buspro
Cable diameter of Buspro terminal	0.6-0.8mm

External Environment

Working temperature	-5°C~45°C
Working relative humidity	≤90%
Storage temperature	-20°C~60°C
Storage relative humidity	≤93%

Specifications

LCD resolution	240x80
Dimensions	86×116.5×10.5 (mm) (Regular) 96×126.5×10.5 (mm) (Larger)
Net weight	129g(Regular), 186g(Larger)
Housing material	Glass, Aluminum, PC, ABS
Installation	Wall box (See Figure 6)
Protection rating (Compliant with EN 60529)	IP20

Approved

CE

RoHS

HDL Buspro Cable Guide

HDL Buspro	HDL Buspro Cable
24V DC	Red
COM	Black
DATA-	White
DATA+	Yellow

Installation

Installation - See Figure 6

Step ①: Install the wall box in the wall.

Step ②: Fix the power interface onto the wall box with screws.

Step ③: Hold the edge of panel, and insert the panel in the slots of power interface vertically.

Technical support

E-mail: hdltickets@hdlautomation.com

Website: <https://www.hdlautomation.com>

©Copyright by HDL Automation Co., Ltd. All rights reserved.
Specifications subject to change without notice.