

Parameters

Electrical Parameters

Input voltage	AC220V±10%
Frequency	50Hz±2%
Power consumption without load	Less than 10W
Output channel	12 channels
Output current in each channel	Up to 10A
Total output current of channels	Less than 120A
Connection	Three phase and five wires

Environment Conditions

Working temperature	-5°C~45°C
Working relative humidity	< 90%
Storage temperature	-20°C~+60°C
Storage relative humidity	< 93%

Approved

CE

RoHS

Product Information

Dimensions	600×290×162(mm)
Net weight	21.8kg
Housing material	Flame-retardant nylon
Installation	Wall mount
Protection rating	IP20

Installation

- **Power cable:** Phase A-Yellow 10mm² copper wire
Phase B-Green 10mm² copper wire
Phase C-Red 10mm² copper wire
- **Line:** Light blue 10mm² copper wire
- **Earth Line of Equipment:** 10mm² copper wire (yellow and green)
- **Load:** 2.5mm² copper wire
- **Buspro connection:** CAT5E or dedicated Buspro cable
- **Fire protection line:** 18AWG double core wire

Important Notes

- Power distribution system should be selected based on the total load.
- Ensure good ventilation and prevent from dampness, shakes and dust.
- Do not approach and interfere with the equipment.
- Ensure power supply.
- (PE) should be connected.
- Overload prohibited.
- Check the connection, avoid wire damage.
- The installation and commissioning of the device must be carried out by HDL or the organization designated by HDL.

Overview



12CH 10A High Power Leading Edge Dimming Actuator is a silicon controlled rectifier module with 12 channels output. The actuator adopts HDL Buspro communication, which has scene controller and fire protection control output. In addition, the load test function can be added to the actuator according to users' requirement. It can be used in intelligence lighting, switch control, etc.

Functions

- 10 Bit dimming accuracy.
- 12-channel dimming outputs.
- LED indicator status indication.
- Scene controller.
- Up to 12 separate areas, each area has 99 scenes and the maximum running time is 60 minutes.
- Up to 99 sequences, each sequence has 99 steps and the time interval is 60 minutes for each step, each sequence has 4 running modes including "forward", "backward", "forward and backward" and "random".
- Low, high, max threshold for each channel.
- Each channel has emergency bypass button and debugging bypass button
- Each scene, area, sequence, channel should mark up.
 - * Each channel has current load detection.
 - * Each channel has MCB status detection.
 - * MCB switch trip alarm.
 - * Broken light alarm.
- Communication: HDL Buspro
- Provides 250mA current(24V DC) for HDL Buspro.
- Fire protection switch.
- Short circuit and overload protection, PE protection.
- Remote programming and management.
- Device can be restored to previous scene or specified scene, sequence.

Note: functions with * are optional.

Dimensions and Wiring

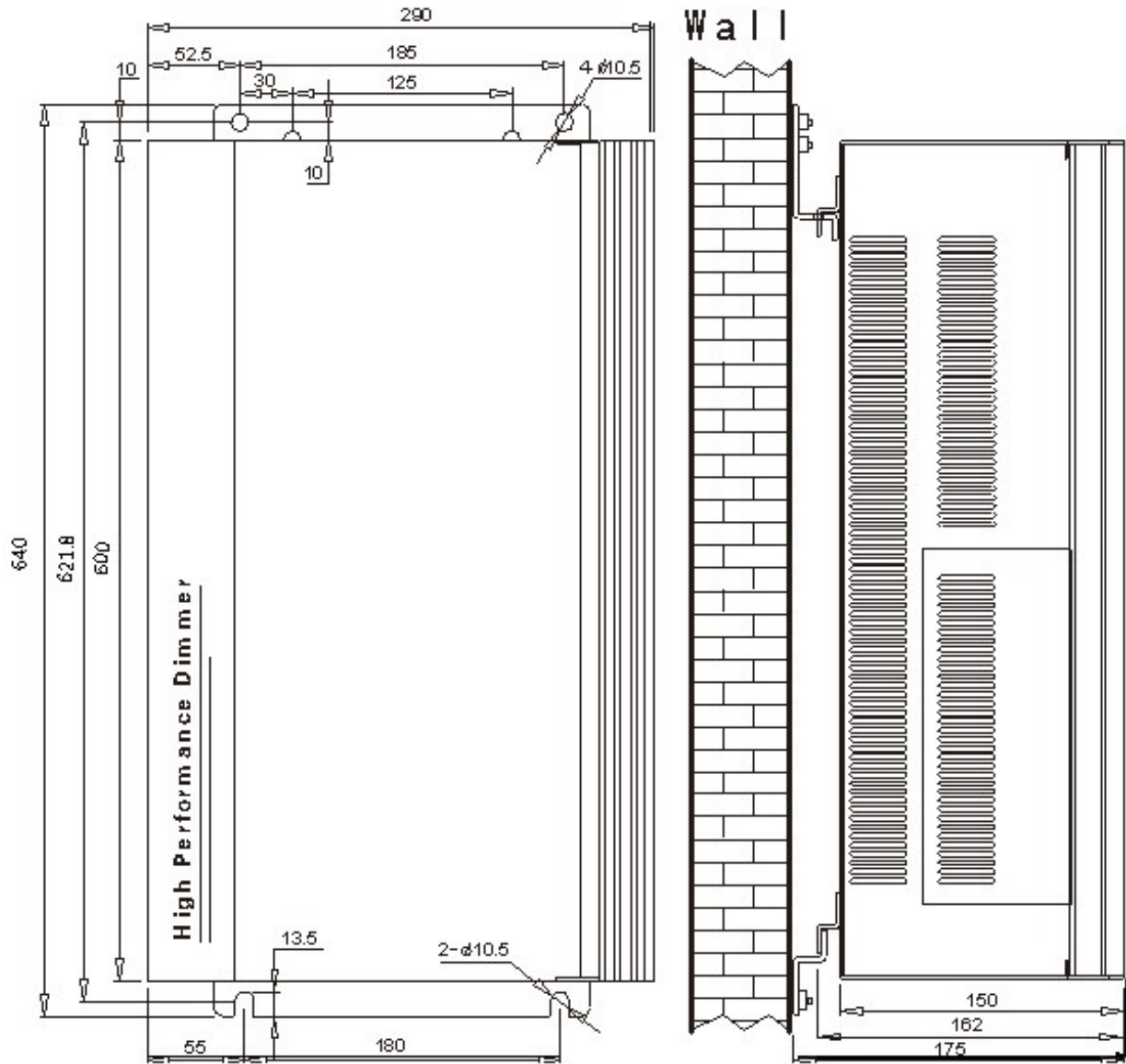

Installation and dimensions (Unit: mm)

Dimensions and Wiring

1. 2 cover board magnets, it is in the inner cover board.
2. Heat dissipation aluminum rod.
3. Cover (can be opened from the left)

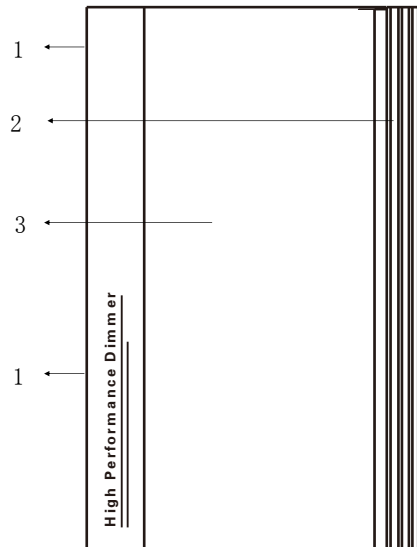

Front

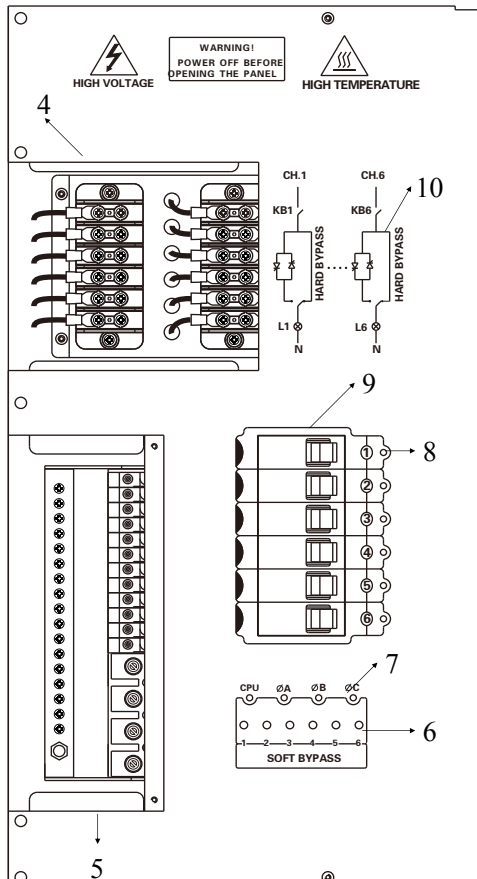

Inside

4. Cover board of jumper wiring
As shown in the figure on the left, it must be open when wiring.
5. Cover board of power input and load wiring
As shown in the figure on the left, it must be open when wiring.
6. Channel control button
12 in total, used for the switch control of Channel 1 to 12 separately.
7. Status indicator
From the left:
CPU indicator - When the device is powered on, the indicator turns on; otherwise keeps off.
Power indicator of phase A - When the device is powered on, the indicator turns on; otherwise keeps off.
Power indicator of phase B - When the device is powered on, the indicator turns on; otherwise keeps off.
Power indicator of phase C - When the device is powered on, the indicator turns on; otherwise keeps off.
8. Channel output signal indicator
12 in total, used for indication of Channel 1 to 12 separately.
9. Load channel switch(16A)
12 in total, used for the load switch control of Channel 1 to 12 separately. The rated current is 16A, it will be closed when over current to the load circuit to protect it.
10. Connection schematic
It has two control types: bypass (default) and silicon controlled rectifier.
The jumper wiring terminal is under the "cover board of 4 jumper wiring". Unscrew and open the cover board to find it, as shown in the figure on the left.
There are 12 terminals (from top to bottom): Channel 1(CH1), Channel 2 (CH2) ...Channel 12(CH12)
11. Jumper terminal of the silicon controlled rectifier channel
12. Output connection terminal
13. Jumper terminal of bypass

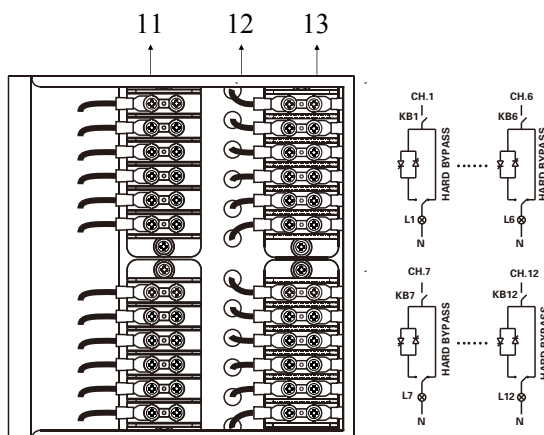

Jumper wiring terminal

Dimensions and Wiring

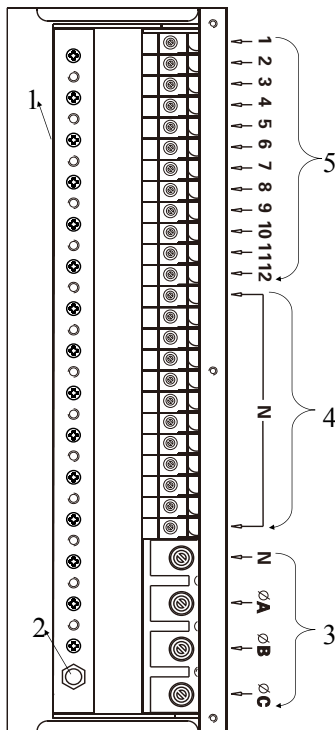

Power input and load wiring terminal

1. Load ground wiring terminal: Connect to load wiring terminal.
2. Ground terminal: Connect to the ground.
3. Power input socket (from top to bottom): N, phase A, phase B, phase C.
4. Null line of Channel 1 to 12 wiring terminal (common terminal).
5. Live line of Channel 1 to 12 wiring terminal (from top to bottom): Channel 1 to 12. Channel 1,4,7,10 are corresponding to phase A, Channel 2,5,8,11 is corresponding to phase B, Channel 3,6,9,12 is corresponding to phase C.

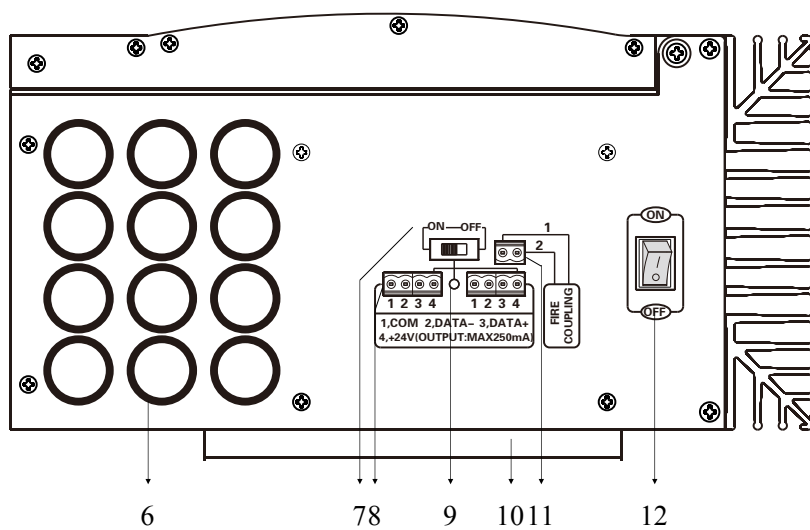

Underside

6. Wiring holes
7. The switch of +24V power output (+24V output is used in HDL Buspro cable)
8. HDL Buspro cable terminal (on both sides)
 - Terminal number definition: 1→COM(common port)
 - 2→DATA-(signal -)
 - 3→DATA+(signal +)
 - 4→24V DC (the max output current is 250mA)
- Definition of CAT5E or HDL Buspro cable and signal:
 - COM→brown white, orange white
 - DATA - →blue white, green white
 - DATA + →blue, green
 - 24V DC →brown, orange
9. +24V output indicator(It will turn on when +24V is outputted)
10. Fixed bracket
11. Terminal socket of fire protection: Connect to fire protection control
12. Power switch (Note: this switch does not affect the +24V power output.)

Dimensions and Wiring

Criterion requirement of multi-branch copper wire terminal

1) Ground wiring terminal

The ground terminal is fixed by the screw. It requires that the terminal should be connected to the appropriate lug and the lug must be connected to the special equipment. As shown in the figure below

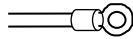

2) Other wiring terminal

The power input, live line and null line should adopt the appropriate cable sheath. The cable sheath should be connected to the special equipment. As shown in the figure below

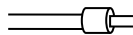

Typical system connection

The typical system connection (for reference only), as shown in the figure below

When connected to control panel (with infrared remote controller), system management server and fire protection management system, the module enables the function of dimming control, switch control, fire protection control, system management and other system control, etc.

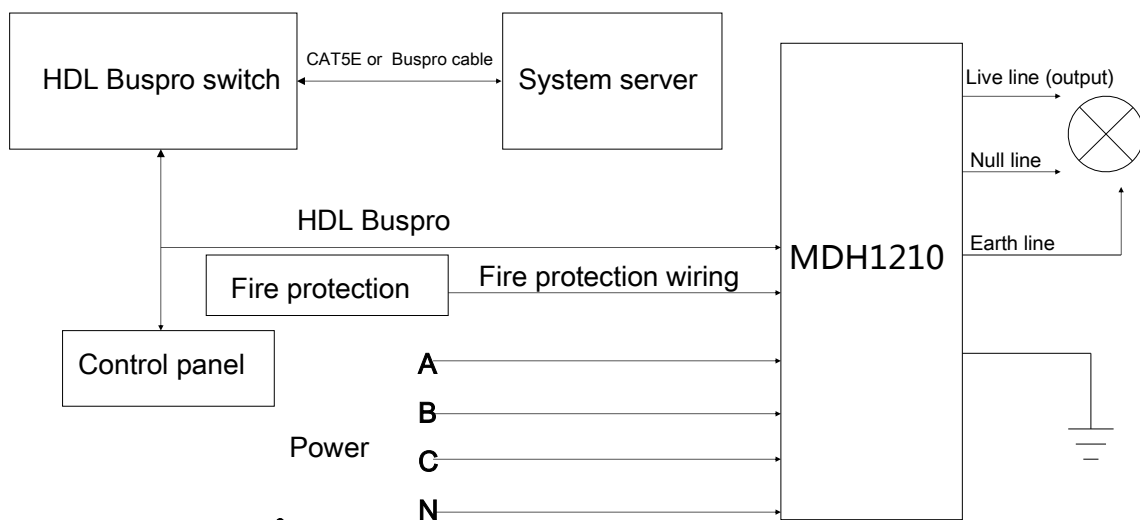

Safety Precautions



- Read all instruction in detail before using.
- Do not approach and interfere with the equipment.
- Ensure power supply.
- (PE) should be connected.
- Overload prohibited.
- Do not make wrong connection on Buspro interface, it will damage the Buspro interface of this module.
- Do not get AC power into Buspro wire, it will damage all devices in the system.
- Avoid contact with liquids and corrosive gases.

Packing List

Device*1 / Mounting support(upper)*1 / Mounting support(lower)*1 / Datasheet*1

